

ISOMETRIC VIEW

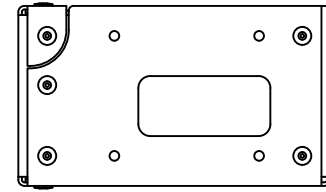

PLAN VIEW

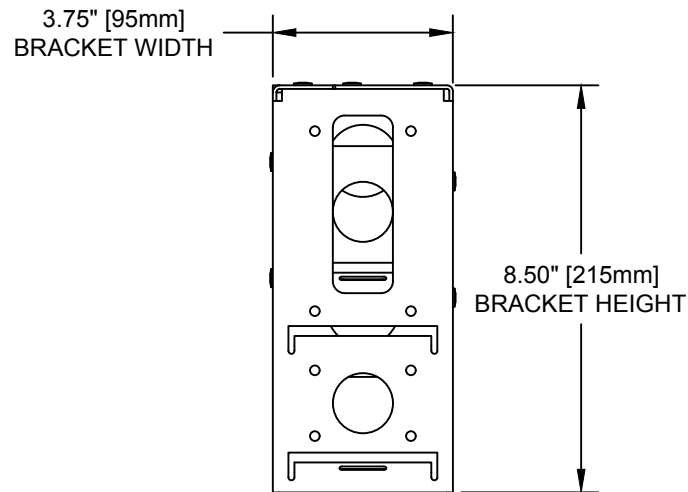

SECTION VIEW

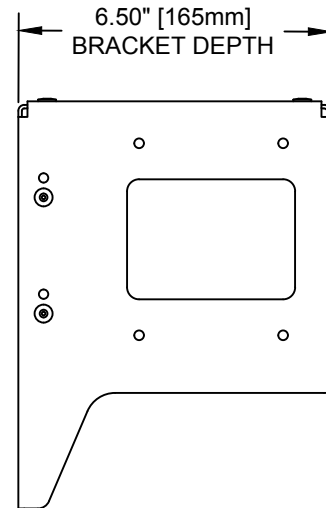

ELEVATION VIEW

ROLLER 100/150/300 DUAL RIGHT SUB-BRACKET

SCALE: 1/4

DRAWING #:

085403

REVISION: A