

EcoSystem® Dimming Power Module: C5-BMJ-16A
EcoSystem® Switching Power Module: C5-XPJ-16A

English

ATTENTION: Please read this guide before installing

 P/N: 032431 Rev. A 03/2013

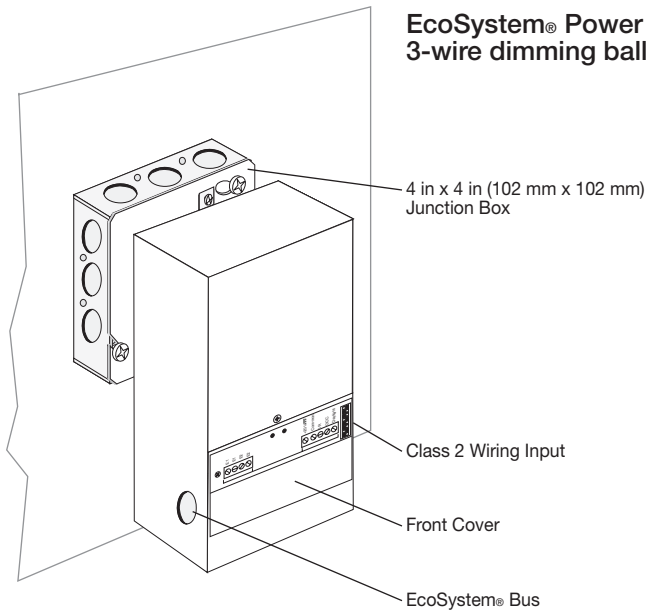

EcoSystem® Power Module for control of Lutron® 3-wire dimming ballasts and non-dim loads.

Specifications

EcoSystem® Power Modules control up to 16 A of Lutron® 3-wire dimming ballasts (Hi-lume® and Eco-10® only) or non-dim loads, and have the following characteristics:

- Input voltage: 100–277 V~ 50/60 Hz
- Maximum switched load: 16 A
- Provides switching output and dimming control (BMJ module only)
- Power Module power draw: 2 VA
- Dimming Power Module provides continuous dimming throughout the ballasts specified range:
 - 500 ft (152 m) maximum wire length between BMJ module and controlled dimming ballast
- Single address on the EcoSystem® Bus
- Accepts up to three sensors, one each of the following types:
 1. Daylight Sensor
 2. Occupant Sensor
 3. Infrared (IR) Receiver or Wallstation

NOTE: It is possible to connect more than 1 ballast or load to a module. The module controls up to 16 A of connected load as a single zone. **If more than one load is attached, the loads cannot be controlled independently.**

Overview

- C5-BMJ-16 Module converts a circuit of one or more Lutron® Eco-10®/Hi-lume® dimming ballast into an EcoSystem® component.
- C5-XPJ-16 Module converts a circuit of non-dim loads into an EcoSystem® component.
- The module connects directly to the EcoSystem® Bus and accepts an occupant sensor, daylight sensor, and infrared wallstation control inputs to drive the attached dimming ballast(s).

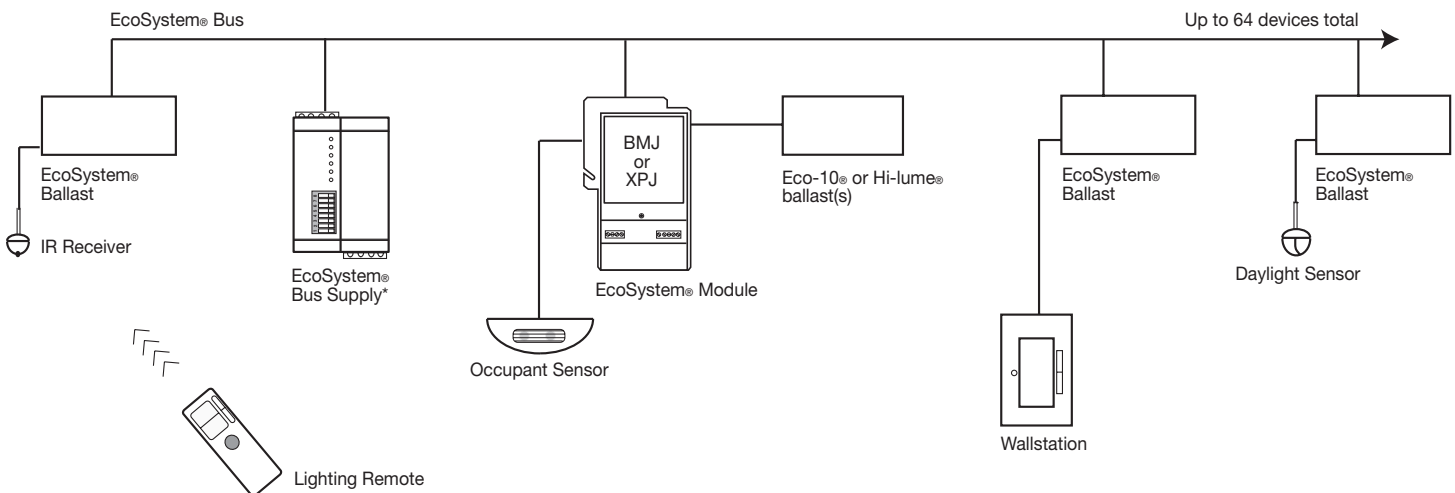

* not counted as one of the 64 devices allowed on the EcoSystem® bus

Installation

Step 1: Determining Mounting Location for Module

- EcoSystem® Power Modules must be mounted onto a 4 in x 4 in (102 mm x 102 mm) standard (1900) junction box (not included, but available: Lutron® P/N 241296). Follow applicable local and national codes.

NOTE: The wire length between the dimming module and the ballast it is controlling shall not exceed 500 ft (152 m).

- Mount the module indoors with ambient temperature between 32 °F and 104 °F (0 °C and 40 °C) and humidity < 90% (non-condensing).



WARNING

Shock Hazard. May result in serious injury or death.
Turn off power at circuit breaker before installing the unit.

DO NOT INSTALL WHILE ENERGIZED. Do not connect any electrically live circuits to the module prior to installation.

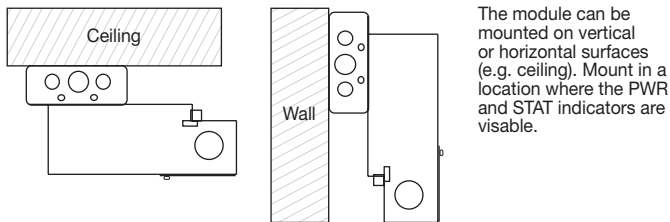
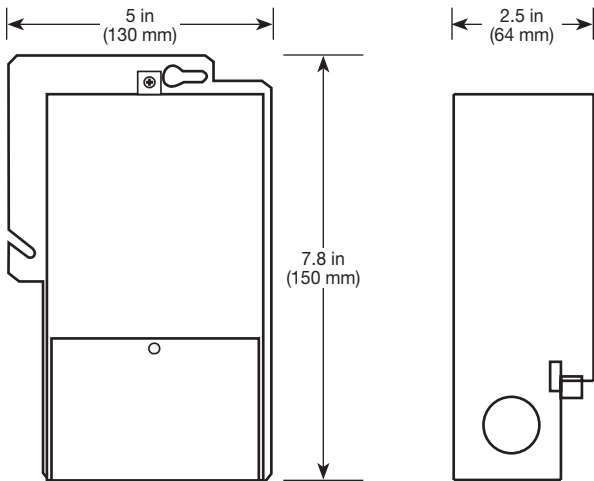

Step 2: Wiring Power Module to Mains and Loads

Live and neutral from a distribution panel is required to power the module.

Lighting loads must match the selected input voltage. Verify that 120 V~ loads are used only with 120 V~ mains, and 277 V~ loads are used only with 277 V~ mains. DO NOT use different voltage loads on the same control circuit.

Dimming Power Module

Three wires are used between the BMJ module and a Hi-lume® or Eco-10® ballast. The wires are color-coded as follows:

C5-BMJ-16A	Ballast	
Red	→ Black	Switched Hot
Orange	→ Orange	Dimmed Hot
White	→ White	Neutral
Green	→ Green	Ground

Switching Power Module

Two wires are used between the XPJ and non-dim loads. The wires are color coded as follows:

C5-XPJ-16A	Load	
Red	→ Black	Switched Hot
White	→ White	Neutral
Green	→ Green	Ground

Module can support up to 16 A of attached switched load current.

Use the following steps to wire a module to mains and ballast(s):

- DO NOT WIRE LIVE. Interrupt power via breaker before wiring between the module and a ballast.
- Connect mains feed wires and output wires to the Power Module as shown in the diagram below.

EcoSystem® Power Module Wiring (See additional ballast installation guides for wire and terminal requirements)

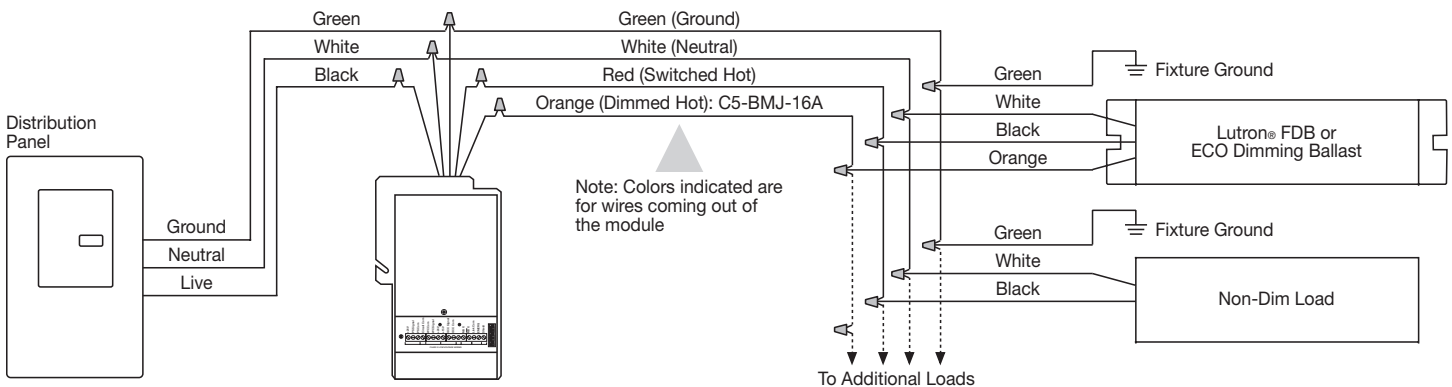

Step 3: Mounting the Module

- Using two screws from the junction box, attach the module to the junction box.
- Be sure all power wires are completely inside the junction box before tightening the mounting screws.
- Turn on breaker to energize the module.
- Attached ballast(s) or loads will turn on to full light output.

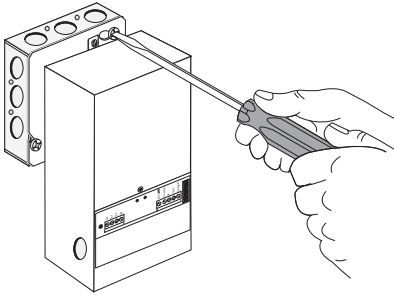

NOTE: If lamp(s) do not turn on, verify that the power (PWR) indicator LED is on; (STAT) indicator will blink if no communication is present.

Step 4: Wiring EcoSystem® Bus

- The EcoSystem® Bus Supply controls up to 64 ballasts and ballast modules. EcoSystem® Bus wiring may be run daisy chain, t-tap, and/or star pattern.
- Bus wiring may be either Class 1 or Class 2.
 - Class 1: Low voltage bus wiring may be run with mains voltage to any fixture the bus is controlling. **NOTE: If wired Class 1, all Class 2 markings must be removed from the link section of the product.** For more information, please read Application Note #142 (www.lutron.com/applicationnotes).
 - Class 2: Low voltage bus wiring must be separated from all mains and Class 1 wiring.
- Consult all applicable national and local codes for compliance.
- Lutron recommends using two different colors for E1 and E2 (EcoSystem® Bus) wire. This helps prevent bus wiring mistakes.

Use the following guidelines for wiring the EcoSystem® Bus to the module:

- DO NOT WIRE LIVE. Interrupt power to the module and the EcoSystem® Bus Supply before wiring and/or servicing the EcoSystem® Bus.
- Connect EcoSystem® Bus wires E1 and E2 to module terminals E1 and E2.
- Energize the EcoSystem® Bus Supply only. Verify that 18 V_{DC} is present at the E1 and E2 terminals on the module.
- Energize the module.
- If there is no power/communication on the link, the status (STAT) LED will blink once per second.

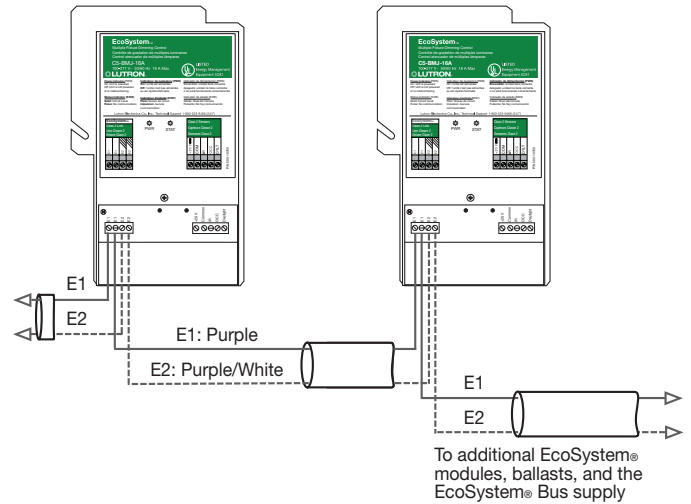

Wire Size and Bus Length

EcoSystem® Bus length is limited by the wire gauge used for E1 and E2 as follows:

Wire Gauge	Bus Length (max)
12 AWG (4.0 mm ²)	2200 ft (671 m)
14 AWG (2.5 mm ²)	1400 ft (427 m)
16 AWG (1.5 mm ²)	900 ft (275 m)
18 AWG (1.0 mm ²)	570 ft (175 m)

Step 5: Wiring Sensor Inputs

If sensors are wired to the module, follow these guidelines:

- Refer to sensor specifications for proper wire gauge and maximum wire distances between the sensor and the module.
- All sensors and wallstations are Class 2 low voltage. Do not combine any sensor wiring with mains wiring.
- Follow all national and local electrical code restrictions when wiring Class 2 devices.
- Wire sensors as instructed by each sensor's instruction sheets.
- Programming of each sensor and wallstation is performed via the EcoSystem® Programmer (C-PDA-CLR)
- Power Module can power only 1 of each type of sensor (occupancy, IR, and daylight). (see next page for wiring diagrams)

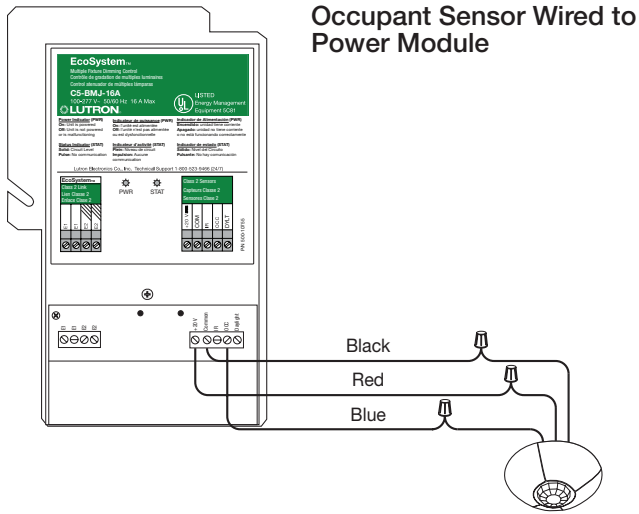

Step 6: Addressing the Power Module (Flash Mode)

- Follow standard procedure for addressing the EcoSystem® Bus
- Each Power Module communicates to the system the same as an EcoSystem® ballast; representing one (1) address location on the EcoSystem® Bus
- Flash Mode (during addressing/programming):
 - C5-BMJ-16A: Device will flash the load(s) by dimming the lights up and down similar to EcoSystem® ballasts.
 - C5-XPJ-16A: Device will flash the load(s) by turning the loads ON and then OFF slowly (non-dim loads). Do not use this module for HID loads as it may damage the lamps.
 - STAT and LED will flash at same rate as the loads.

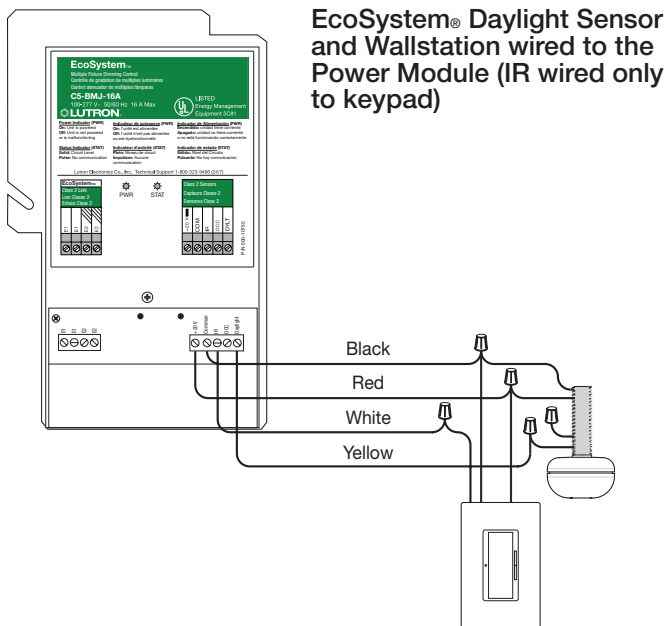

Step 7: Troubleshooting Module not responding

If the module, attached ballasts, and lamps are fixed at full-light output, will not dim, and can not be turned off, the Power Module is likely in emergency mode or is not communicating. If there is no communication, the status (STAT) LED will blink. Verify that the EcoSystem® Bus wiring is properly terminated, powered via the EcoSystem® Bus Power Supply, and 18 V_{DC} is present between the E1 and E2 terminals on the Power Module.

Lights Not Dimming

If the lights switch only between off and full-light output:

- Verify the wiring between the module and the ballast.
- Verify that the device is a C5-BMJ-16A, because the C5-XPJ-16A does not offer dimming control.

Lights Stay at Low-End:

- Make sure Dimmed Hot is connected (C5-BMJ-16A only).
- If most of the ballasts are at low-end and one or more ballasts are OFF, there is a miswire between Hot and Dimmed Hot at one of the ballasts that is OFF. Verify wiring.

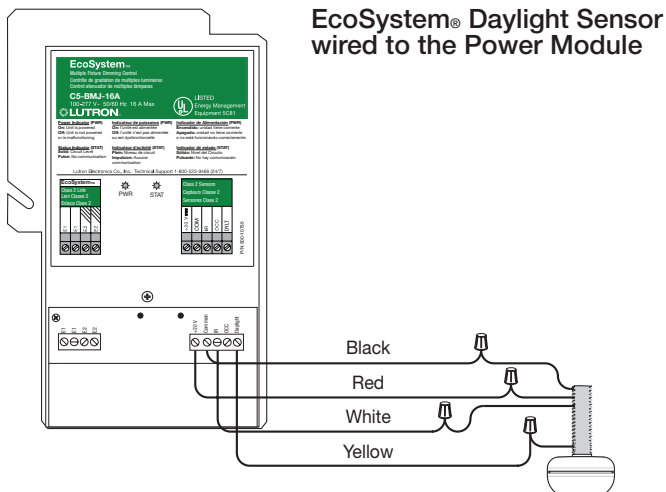

Lutron, EcoSystem, Eco-10, and Hi-lume are registered trademarks of Lutron Electronics Co., Inc.

© 2013 Lutron Electronics Co., Inc.

Lutron Electronics Co., Inc.
7200 Suter Road
Coopersburg, PA 18036-1299
USA