

Visor Control Receiver	DC Adapter
HQR-VCRX	Included (T120-9DC-3-BL)
HQR-VCRX-WH-BA	Not included (See Lutron® P/N 369561)

Visor Control Receiver: 9 V \equiv 300 mA
DC Adapter (T120-9DC-3-BL): Power Jack (to DC adapter) (IEC PELV/NEC \circ Class 2) \ominus \oplus
Input: 120 V \sim 60 Hz 6.5 W **Output:** 9 V \equiv 300 mA
Visor Control Transmitter: LR-3B-H 3 V \equiv 10 mA
Typical Power Consumption: 1.6 W
 Typical Power Consumption test conditions: two LEDs on (two presets active), Receiver powered by the 9 V \equiv adapter (T120-9DC-3-BL), no CCOs or CCI active.

Installation Instructions Please Read Before Installing

Use these instructions to install the model numbers listed above.

Features

- Works with Visor Control Transmitter (LR-3B-H - sold separately) and HomeLink \circ compatible buttons found in many vehicles.
- Provides two Contact Closure Inputs (CCI) for integration with other systems and one CCI intended for emergency systems (security, fire, etc.) or applications requiring a maintained contact closure and the ability to toggle the system programming from a Visor Control Transmitter.
- Provides four Contact Closure Outputs (CCO) to control up to four garage doors or motorized gates.
- Up to 10 Transmitters can be used with a Receiver.
- Each output can be controlled locally at the Receiver, remotely by a Transmitter, or from any system keypad or event.
- Includes pre-printed and blank labels for naming scenes/buttons.

Important Notes

WARNING - Entrapment Hazard - This device must not be used to control equipment that is not visible from every control location. It also must not be used to control equipment that could create hazardous situations such as entrapment if operated accidentally. Examples of equipment that must not be controlled by this device include (but are not limited to) motorized gates, garage doors, industrial doors, microwave ovens, heating pads, etc. It is the installer's responsibility to ensure that the equipment being controlled is visible from every control location and that only suitable equipment is connected to this device.

Environment

Visor Control Receiver:
 Ambient operating temperature: 32 °F to 140 °F (0 °C to 60 °C), 0% to 90% humidity, non-condensing. Indoor use only.
Visor Control Transmitter:
 Ambient operating temperature: -40 °F to 235 °F (-40 °C to 113 °C), 0% to 90% humidity, non-condensing. Meets the Society of Automotive Engineers (SAE) temperature standards.

Codes
 Install in accordance with all local and national electrical codes.

Cleaning
 To clean, wipe with a clean damp cloth. DO NOT use any chemical cleaning solutions.

Visor Control Receiver DC Adapter Power
NOTICE - Using a DC adapter not rated at the proper specifications could damage the Receiver and possibly overheat the DC adapter. Use only the DC adapter listed above.

RF Device Placement
 RF devices must be located within 30 ft (9 m) of an RF signal repeater. Remote dimmers and switches are not required to be within a specific range of a repeater.

System Programming
 Programming and activation (addressing) must be accomplished through the HomeWorks \circ QS software.

Installation of a Visor Control Receiver

1. Find a suitable location for the Receiver within 30 ft (9 m) of a repeater.
2. Mount vertically or horizontally, as shown in the **Mounting Diagram**, using two #6 (M3) screws (included). When mounting, allow 7 in (177.8 mm) clearance for the antenna and ensure convenient access to the contact closures and front buttons. In order to achieve proper RF performance, do not mount unit in a metal enclosure.
3. Attach the DC adapter cord to the power jack on the Receiver and insert the DC adapter plug into a receptacle.

Installation of a Visor Control Transmitter

1. Attach the visor clip to the Transmitter as shown in the **Transmitter Diagram**.
2. Mount the Transmitter onto a vehicle's visor.

Technical Assistance:
 U.S.A./Canada: 1.800.523.9466
 Mexico: +1.888.235.2910
 Brazil: +55 11 3257 6745
 United Kingdom: +44.(0)20.7680.4481
 India: +91.124.471.1900

United Arab Emirates: +971.4.299.1224
 China: 10.800.120.1536
 Singapore: 800.120.4491
 Other Countries: +1.610.282.3800

Dimensions Measurements shown as: in (mm).

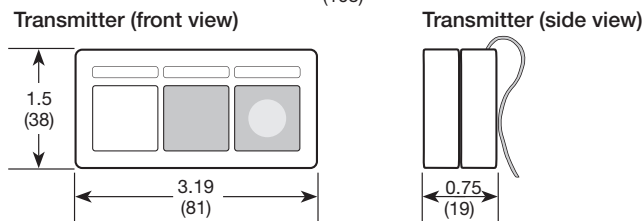
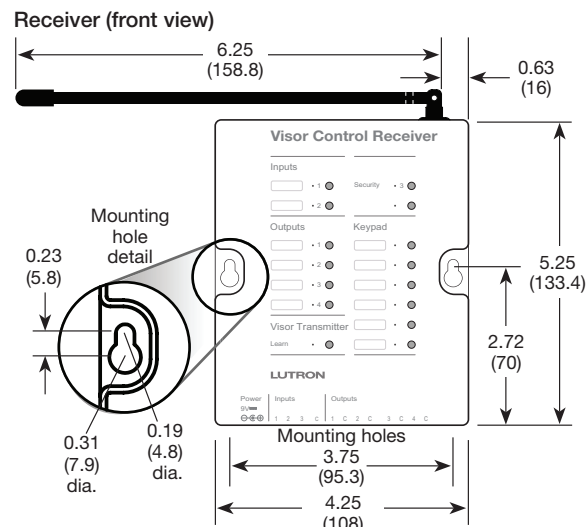

Mounting Diagram

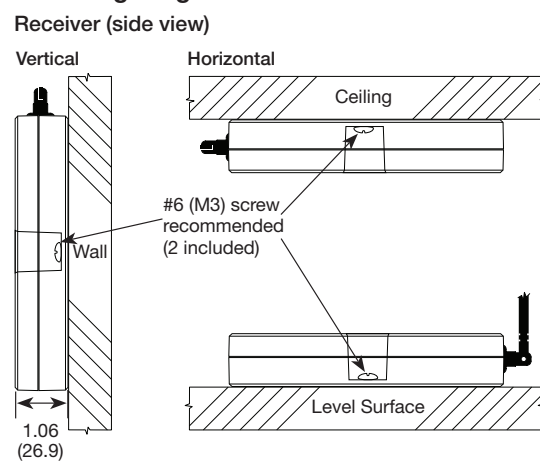

Connection Diagram

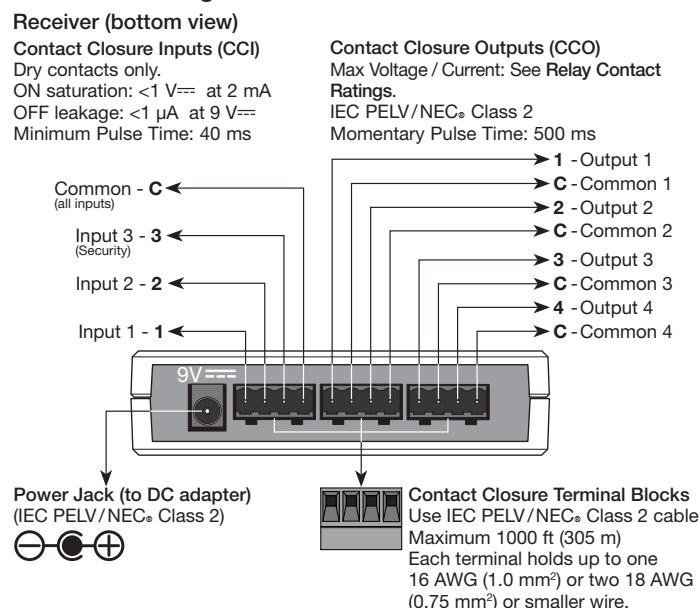

Relay Contact Ratings

Voltage	Resistive Load	Inductive Load
Up to 30 V \equiv	1 A	0.2 A
Up to 30 V \sim	1 A	0.1 A
Up to 60 V \equiv	0.5 A	Do not use

Normal Operation
Visor Control Receiver

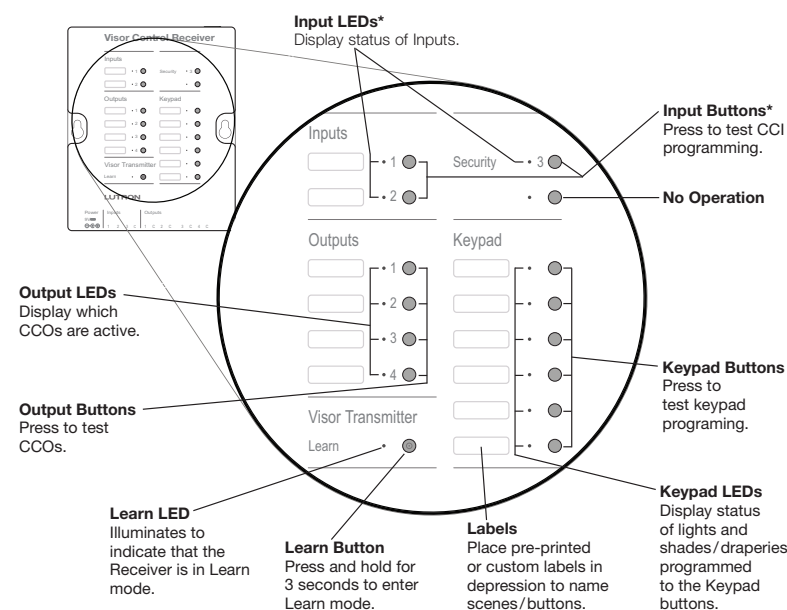

*The Security CCI (Input 3) is a special purpose input typically used to interface to security, fire, or other emergency systems that tend to use maintained closures. This permits a transmitter button to **toggle** into and out of security mode. In order to activate this closure from the transmitter or input button, press and hold the button for 6 seconds.

Visor Control Transmitter

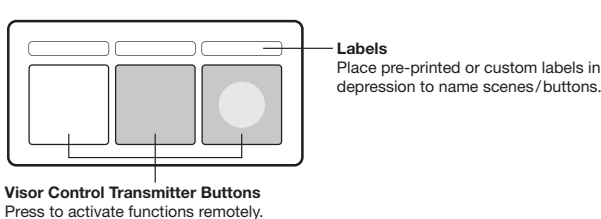

Transmitter (back view)

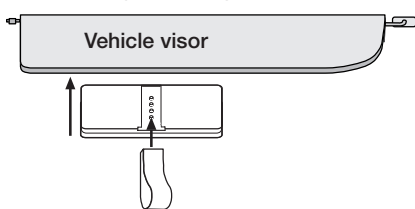

Learning Transmitter Buttons to a Receiver

- Note: Learning Transmitter buttons to a Receiver allows functions on a Receiver to be remotely activated by a Transmitter.*
1. Press and hold the Learn button on a Receiver until the Learn LED turns on solid (approximately three seconds).
 2. Press and release the button on a Receiver that is to learn a Transmitter button. The selected button's LED will turn on solid.
 3. Press and hold the desired Transmitter button until the LED next to the selected Receiver button begins to flash rapidly (approximately three seconds). The Learn LED on the Receiver will also flash rapidly while the Transmitter button is pressed.

Troubleshooting Guide

Symptom	Probable Cause and Action
The system does not respond to the Visor Control Receiver or Transmitter.	<p>Power Not Present</p> <ul style="list-style-type: none"> • Ensure that the power supply cord is plugged into a wall outlet and the power jack on the Receiver. • Circuit Breaker is OFF or tripped. Reset or turn on circuit breaker. <p>System devices are not programmed correctly.</p> <ul style="list-style-type: none"> • Program all devices using the HomeWorks\circ QS software. <p>System devices are not within specified RF range.</p> <ul style="list-style-type: none"> • Ensure that dimmers, keypads and shades/ draperies are within 30 ft (9 m) of a repeater. • Verify that all repeaters are within 60 ft (18 m) of another repeater. • Make sure that the Receiver is within 30 ft (9 m) of a repeater. • Wait until the Transmitter is within 150 ft (46 m) of the Receiver before pressing a button on the Transmitter.
Receiver is not programmed correctly.	<ul style="list-style-type: none"> • Program the device using the HomeWorks\circ QS software.
Contact Closure Inputs (CCI) not connected properly.	<ul style="list-style-type: none"> • Refer to the Connection Diagram.
The Transmitter is not programmed correctly.	<ul style="list-style-type: none"> • See the Learning Transmitter Buttons to a Receiver section to program the Transmitter.
Contact Closure Outputs (CCO) not connected properly.	<ul style="list-style-type: none"> • Refer to the Connection Diagram.
Dead, low, or no batteries in the Transmitter.	<ul style="list-style-type: none"> • Install new batteries in the Transmitter (CR2032)
All LEDs on the keypad flash when any button is pressed.	<ul style="list-style-type: none"> • The device is in the Factory Default Settings mode and has not been activated into the system. Use the HomeWorks\circ QS software to verify activation or re-activate the device and transfer its database.
LEDs on the Receiver do not turn on when it is powered up.	<p>Improper adapter used.</p> <ul style="list-style-type: none"> • Use the DC adapter provided with the Receiver or see Lutron\circ P/N 369561.
Top keypad LED on the Receiver is flashing rapidly.	<p>Improper adapter used.</p> <ul style="list-style-type: none"> • Use the DC adapter provided with the Receiver or see Lutron\circ P/N 369561.

Remove all Visor Control Transmitters from the Visor Control Receiver

Note: Removing the Transmitters from the Receiver will remove the capability to activate functions on the Receiver remotely but will not remove programming from the Receiver. The Transmitters will need to be reprogrammed to a Receiver.

1. Triple tap and hold the Learn button on the Receiver. DO NOT release the button after the third tap.
2. Keep the button pressed on the third tap until the Learn LED starts to flash slowly (approximately three seconds).
3. Release the button and immediately triple tap it again. The Learn LED will flash quickly. When the LED stops flashing, all of the Transmitters have been removed from the Receiver.

Returning a Visor Control Receiver to Factory Settings

Note: Returning the Receiver to factory settings will erase all system programming from the Receiver and will require the Receiver and all Transmitters to be reprogrammed into a system.

1. Triple tap and hold any button (except the Learn button) on a Receiver. DO NOT release the button after the third tap.
2. Keep the button pressed on the third tap until the LED(s) start to flash slowly (approximately three seconds).
3. Release the button and immediately triple tap it again. The LEDs will flash quickly. When the LEDs stop flashing, the Receiver has been returned to factory settings.

Warranty: For warranty information, please see the Warranty enclosed with the product, or www.lutron.com/TechnicalDocumentLibrary/HomeWorks_Warranty.pdf

