

## EcoSystem Load Support for Non-EcoSystem Load Types

---

The Lutron EcoSystem protocol uses individual fixture addressing for maximum flexibility in any given application. While EcoSystem is available natively on a wide variety of Lutron fluorescent ballasts and LED drivers, it is oftentimes necessary to control a Lutron 3-wire, switching, phase-control, or 0–10 V<sub>DC</sub> load on a project. This application note will explain how these loads can be controlled using various Lutron load control interfaces.

### General Guidelines:

Each EcoSystem interface device consumes one EcoSystem address.

### Table of Contents:

#### 1. Lutron 3-Wire Load Support with EcoSystem

- a. Overview
- b. Wiring diagram
- c. Design considerations

#### 2. Switching Load Support with EcoSystem

- a. Overview
- b. Wiring diagram
- c. Design considerations

#### 3. Phase Adaptive Load Support with EcoSystem

- a. Overview
- b. Wiring diagram
- c. Design considerations

#### 4. 0–10 V<sub>DC</sub> Load Support with EcoSystem

- a. Overview
- b. Wiring diagram
- c. Design considerations

## Lutron 3-Wire Load Support with EcoSystem

The C5-BMJ-16A is a module that converts EcoSystem control to 3-wire dimming control. This interface is intended to control Lutron 3-wire ballasts and drivers. The C5-BMJ-16A is powered by 100–277 V $\sim$  and controls 16 A of load.

The C5-BMF-2A is also a module that converts EcoSystem to 3-wire dimming control. This interface is intended to control a single fixture (up to 2 A of load). The C5-BMF-2A is powered by 120–277 V $\sim$ .

### Wiring the C5-BMJ-16A to a Lutron 3-Wire Dimming Ballast or Driver

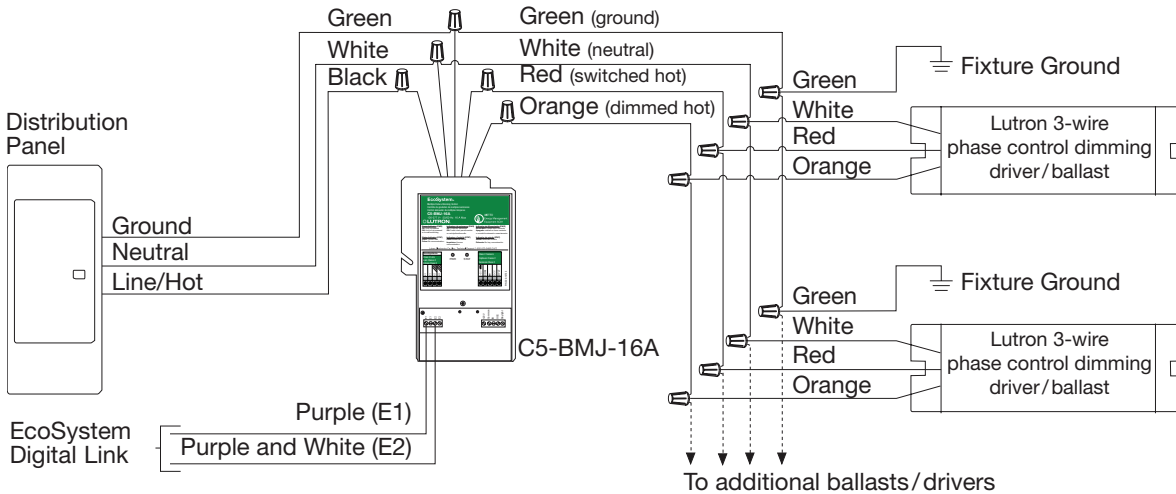

## Lutron 3-Wire Load Support with EcoSystem (continued)

### Wiring C5-BMF-2A to Lutron 3-Wire Dimming Ballast or Driver

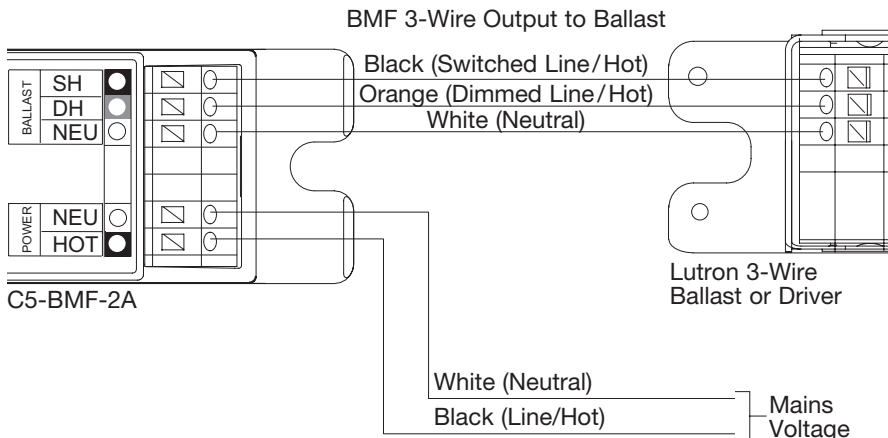

#### Line Voltage Driver / Ballast Terminals

##### BMF output to Lutron Drivers/Ballasts:

- 18 AWG to 16 AWG (0.75 mm<sup>2</sup> to 1.5 mm<sup>2</sup>) solid wire
- Maximum distance module to ballast: 25 ft (7.6 m)
- Terminal Colors:
  - Black = Switched Line/Hot (HOT)
  - Orange = Dimmed Line/Hot (DH)
  - White = Neutral (NEU)

##### Mains voltage input terminals:

- 18 AWG to 16 AWG (0.75 mm<sup>2</sup> to 1.5 mm<sup>2</sup>) solid wire connects to facility distribution wiring.

### Wiring C5-BMF-2A to EcoSystem Digital Link

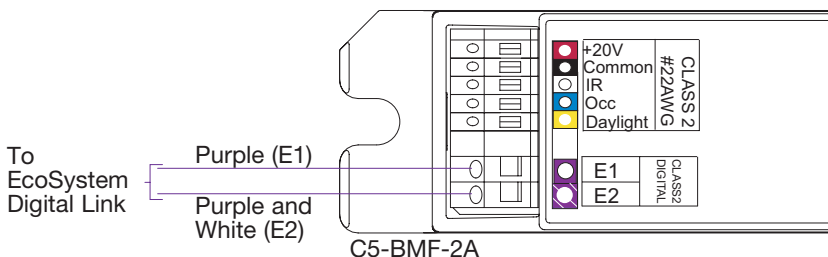

#### Low Voltage Driver / Ballast Terminals

##### Class 2 Low Voltage Sensors/Controls

- 22 AWG (0.32 mm<sup>2</sup>) solid wire only in module terminals
- Maximum distance from module to sensor/keypad is 100 ft (30.5 m)

##### EcoSystem Digital Link

- 18 AWG to 16 AWG (0.75 mm<sup>2</sup> to 1.5 mm<sup>2</sup>) solid wire at E1 and E2 terminals
- Connect up to 64 ballasts and modules on the EcoSystem Digital Link
- EcoSystem Digital Link wiring between modules can be a larger wire gauge to support longer digital link length, but each module terminal only accepts one 18 AWG to 16 AWG (0.75 mm<sup>2</sup> to 1.5 mm<sup>2</sup>) solid wire

#### Design Considerations:

- In the programming software, the EcoSystem load type that the BMJ or BMF module is programmed to should be set for a low-end trim of 10%, and a high-end trim of 90%. In Quantum, the load type is called “EcoSystem Ballast Module” and has the trim levels already setup.
- Multiple loads connected to a single BMJ or BMF module cannot be controlled independently. All loads are controlled as a single EcoSystem address.

For more information, see the technical documentation for the C5-BMJ-16A and C5-BMF-2A:

#### C5-BMJ-16A

Specification submittal: 369617

Installation guide: See **EcoSystem Power Module - Junction Box Mount Install Guide** at [www.lutron.com](http://www.lutron.com)

#### C5-BMF-2A

Specification submittal: [http://www.lutron.com/TechnicalDocumentLibrary/c5\\_bmf\\_2a.pdf](http://www.lutron.com/TechnicalDocumentLibrary/c5_bmf_2a.pdf)

Installation guide: See **EcoSystem Ballast Module Fixture Mount Install Guide** at [www.lutron.com](http://www.lutron.com)

## Switching Load Support with EcoSystem

The C5-XPJ-16A is a module that uses EcoSystem control to integrate non-dim loads.

### Line Voltage Wiring Using C5-XPJ-16A

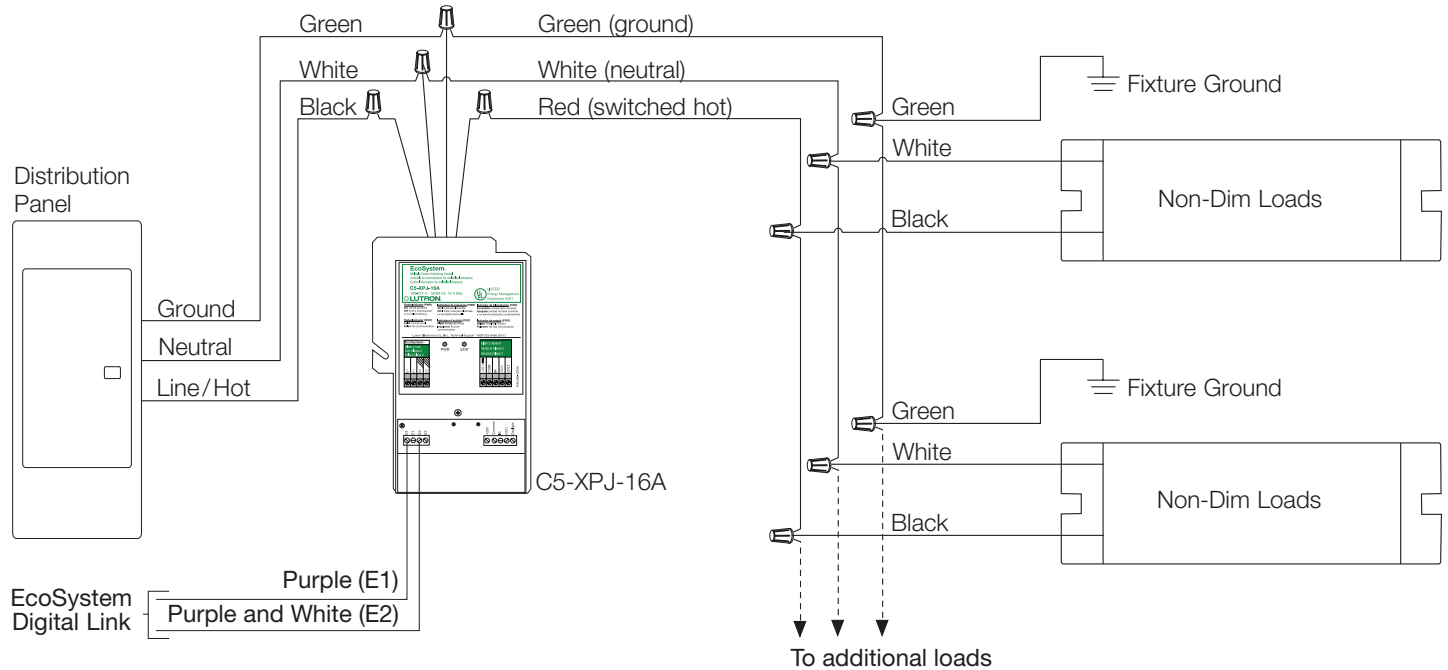

### Design Considerations:

- The XPJ module is not compatible with PowPak EcoSystem devices. In this application, use a PowPak Relay Module with SoftSwitch.
- The XPJ module is not suitable for switching general purpose receptacle loads.
- Multiple loads connected to a single XPJ module cannot be controlled independently. All loads are controlled as a single EcoSystem address.
- Lutron switching controls are designed to switch loads that meet the NEMA® 410 standard for inrush current. Circuits loaded with noncompliant ballasts and drivers may result in nuisance tripping of circuit breakers and control failure. Please ensure that all lighting loads meet the NEMA® 410 spec to help ensure successful operation.

For more information, see the technical documentation for the C5-XPJ-16A:

Specification submittal: 369409

Installation guide: See **EcoSystem Power Module – Junction Box Mount Install Guide** at [www.lutron.com](http://www.lutron.com)

## Phase-Adaptive Load Support with EcoSystem

The following section describes how to control phase control load types. This includes Reverse Phase (Electronic Low-Voltage [ELV]) and Forward-Phase (Magnetic Low-Voltage [MLV], Incandescent, Halogen, Neon/cold cathode, and Lutron 2-wire LED drivers).

The C5-BMJ-16A is a module that converts EcoSystem control to 3-wire dimming control. While this interface is intended to control Lutron 3-wire ballasts and drivers, it can also be used with the PHPM-WBX, Lutron 3-wire interface.

The PHPM-WBX takes a Lutron 3-wire control signal input<sup>1</sup> and outputs a 2-wire phase-adaptive (forward-phase or reverse-phase) dimming signal. This differs from the other commonly used power module, the PHPM-PA, which takes a 2-wire phase-control input, and outputs a 2-wire phase-adaptive dimming signal.

The PHPM-WBX has 3 primary variations:

**Note:** Control voltage of the PHPM is equivalent to the voltage that the C5-BMJ-16A is powered with for the purposes of this document.

### 1.PHPM-WBX-120-WH

- Control voltage = 120 V~
- Load voltage = 120 V~

### 2.PHPM-WBX-DV-WH

- Control voltage = 120 V~
- Load voltage = 120–277 V~

### 3.PHPM-WBX-277/DV

- Control voltage = 220–277 V~
- Load voltage = 120–277 V~

As shown above, the difference between the two standard part numbers, PHPM-WBX-120 and PHPM-WBX-DV, is load-side voltage capability. The –DV unit is capable of controlling 120–277 V~ loads, whereas the -120 unit can only control 120 V~ lighting. Both of these units can only accept 120 V~ control input, meaning that 277 V~ lighting control inputs cannot be used on either of these units. The PHPM-WBX-277/DV was designed to accept 277 V~ control inputs from a C5-BMJ. This unit **must** be specified when the controlling BMJs are powered by 277 V~.

Special care must be taken into account when specifying a solution for project's utilizing both 120 V~ and 277 V~ for lighting. Ensure that both the voltage for the lighting and the BMJ are known, as either of these can affect the choice of power module needed.

<sup>1</sup> PHPM only need the dimmed hot and neutral connections from a Lutron 3-wire control.

# Phase-Adaptive Load Support with EcoSystem (continued)

## Single 120 V~ Power Feed for Control and Load

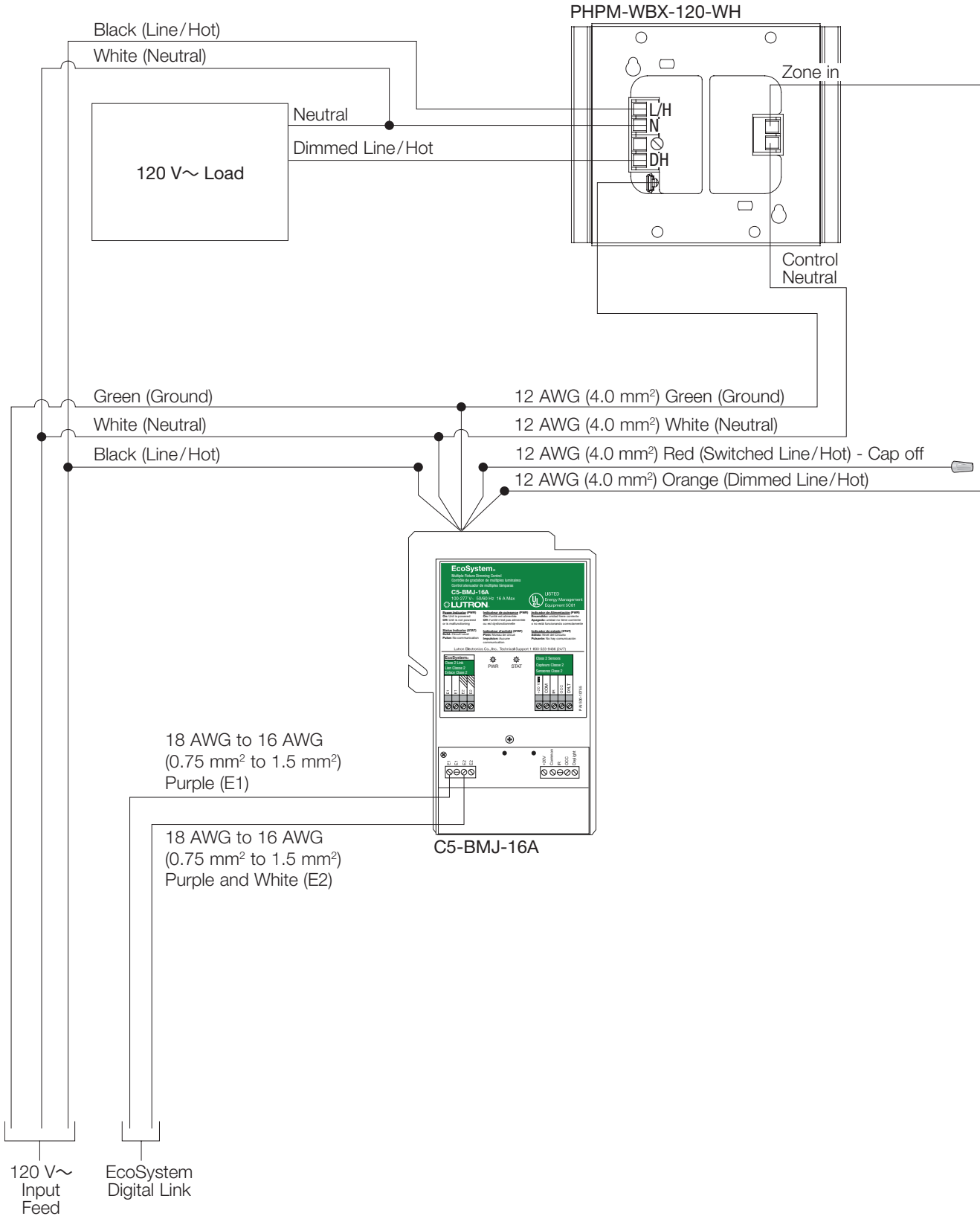

# Phase-Adaptive Load Support with EcoSystem (continued)

## Single 277 V~ Power Feed for Control and Load

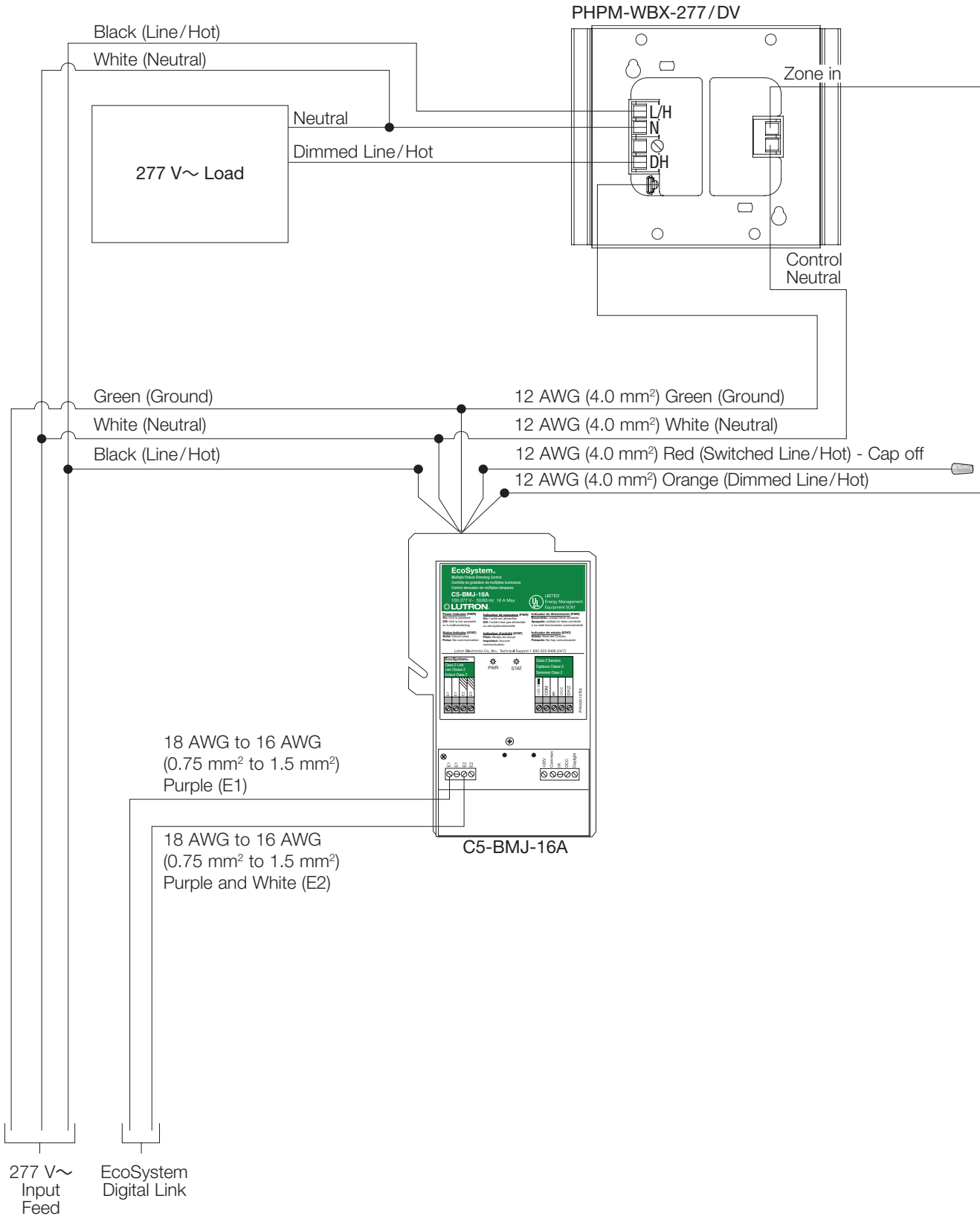

## Phase-Adaptive Load Support with EcoSystem (continued)

### Separate Power Feeds for Control and Load: 120 V~ Control Voltage

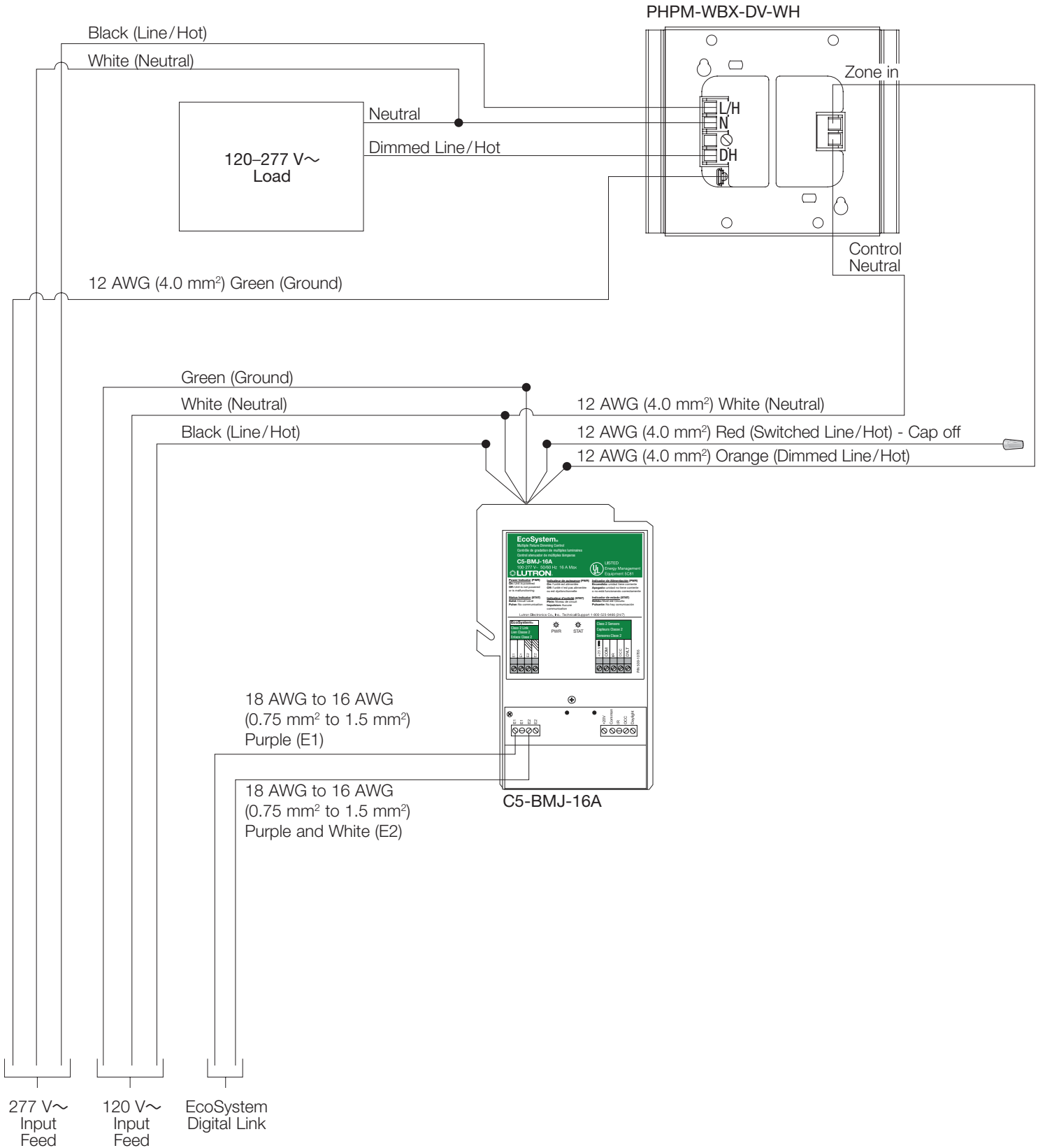



## Phase-Adaptive Load Support with EcoSystem *(continued)*

### Design Considerations:

- Only one PHPM-WBX may be placed on a single C5-BMJ-16A output.
- Minimum load required on a PHPM-WBX is 10 W.
- Multiple loads connected to a single PHPM-WBX module cannot be controlled independently. All loads are controlled as a single EcoSystem address.
- In the programming software, the EcoSystem load type that the BMJ is programmed to should be set for a low-end trim of 10%, and a high-end trim of 90%. In Quantum, the load type is called “EcoSystem Ballast Module” and has the trim levels already setup.
- Load-side switching is not recommended on outputs driving power modules or on the output of the PHPM.

### For more information see the technical documentation for the PHPM-WBX:

Specification submittal: 369358

Installation guide: See **Phase Adaptive Power Module with 3-Wire Fluorescent Input Install Guide** at [www.lutron.com](http://www.lutron.com)

## 0–10 V<sub>DC</sub> Load Support with EcoSystem

The TVI-LMF-2A is a module that converts EcoSystem control to 0–10 V<sub>DC</sub> control. It allows for individual addressing of a 0–10 V<sub>DC</sub> device, but provides only one way communication from the controls to the 0–10 V<sub>DC</sub> device. This interface is intended for single fixture control only, due to its current sinking and distance limitations of 10 ft (3 m).

For larger 0–10 V<sub>DC</sub> loads, the GRX-TVI can be used in conjunction with a C5-BMJ-16A. The GRX-TVI is a module that takes a Lutron 3-wire control input and outputs a 0–10 V<sub>DC</sub> dimming signal. The GRX-TVI is capable of being powered by a 100–277 V<sub>AC</sub> signal.

### Single Fixture Control (up to 2 A and up to 25 mA sink current) using TVI-LMF-2A for 120 V<sub>AC</sub>, 220–240 V<sub>AC</sub>, 277 V<sub>AC</sub>

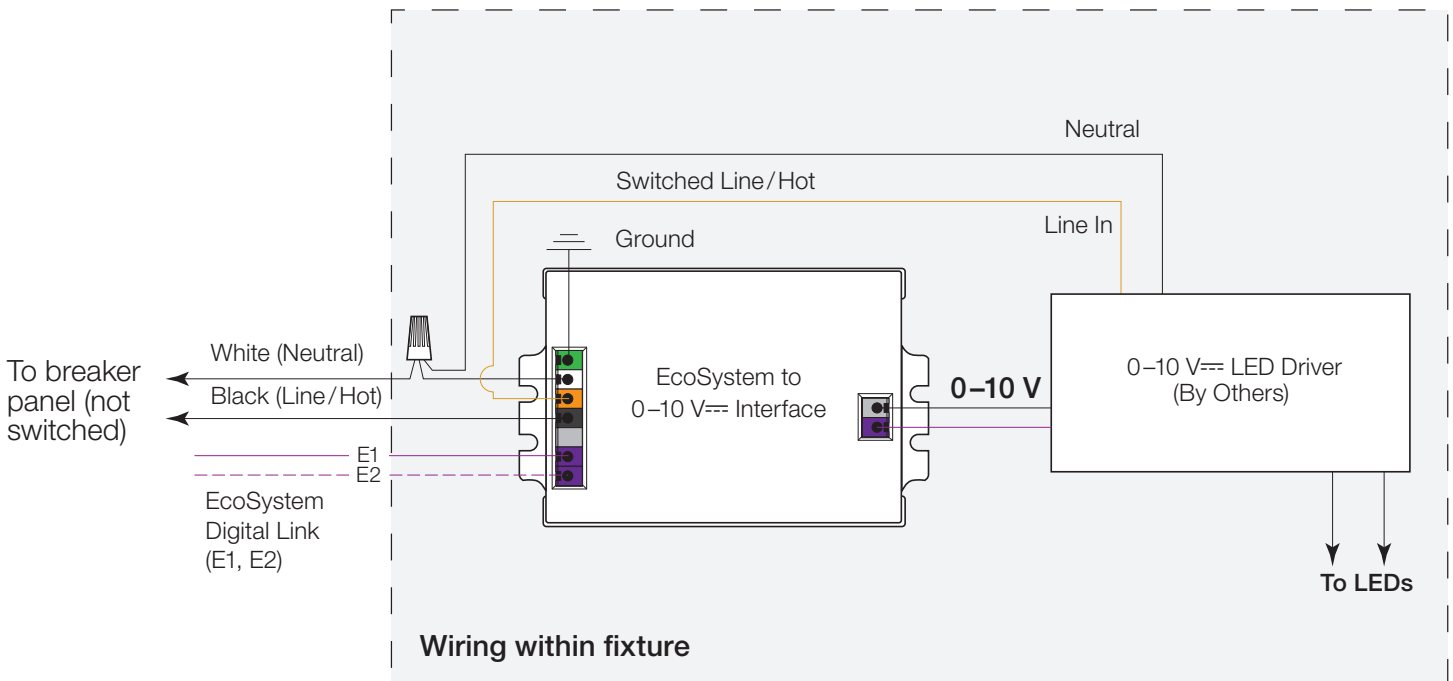

## 0–10 V<sub>DC</sub> Load Support with EcoSystem (continued)

### Single Circuit Fixture Control (up to 16 A and up to 300 mA sink current) Using C5-BMJ-16A and GRX-TVI

L2/H2 terminals are tied to each other internally. It is the Line/Hot feed that powers the internal circuitry of the GRX-TVI. Use the appropriate voltage in the range of 100–277 V<sub>AC</sub>. Refer to the **Note** on the first page of the GRX-TVI Specification Submittal 369247.

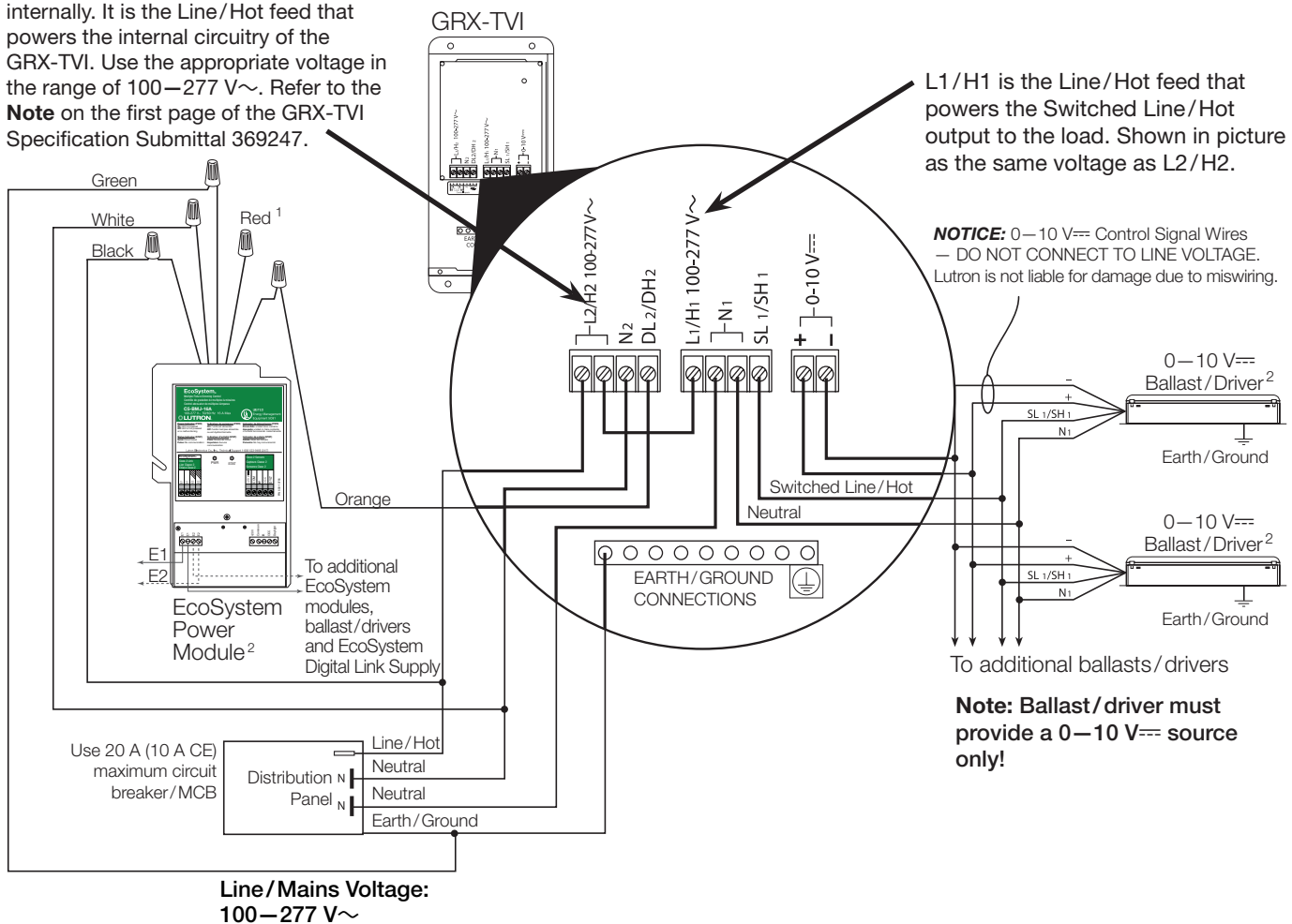

<sup>1</sup> The red wire is not used. Cap off the red wire using a wire connector. Do not wire the red wire to ground or to any other wiring.  
<sup>2</sup> Ballasts/drivers must be rated for the specific Line/Mains voltage utilized.

#### Design Considerations:

- Only one GRX-TVI can be connected to the output of a C5-BMJ-16A.
- Multiple loads connected to a single GRX-TVI or TVI-LMF-2A module cannot be controlled independently. All loads are controlled as a single EcoSystem address.
- Lutron 0–10 V<sub>DC</sub> lighting controls are designed to switch loads that meet the NEMA<sup>®</sup> 410 standard for inrush current. Circuits loaded with non-compliant ballasts and drivers may result in nuisance tripping of circuit breakers and control failure. Please ensure that all lighting loads meet the NEMA<sup>®</sup> 410 spec to help ensure successful operation.
- **Important Note:** TVIs made on or before date code W6 do not support reverse or center phase and will not work in the application above.

For more information see the technical documentation for the TVI-LMF-2A:

Specification submittal: 369537

Installation guide: See **EcoSystem to 0-10 V Interface Install Guide** at [www.lutron.com](http://www.lutron.com)

For more information see the technical documentation for the GRX-TVI:

Specification submittal: 369247

Installation guide: See **GRX-TVI Install Guide** at [www.lutron.com](http://www.lutron.com)

Lutron, EcoSystem, PowPak, Quantum, SoftSwitch, and Tu-Wire are trademarks or registered trademarks of Lutron Electronics Co., Inc. in the US and/or other countries.

NEMA is the registered trademark and service mark of the National Electrical Manufacturers Association

---

## Lutron Contact Numbers

### WORLD HEADQUARTERS

**USA**  
**Lutron Electronics Co., Inc.**  
**7200 Suter Road**  
**Coopersburg, PA 18036-1299**  
TEL: +1.610.282.3800  
FAX: +1.610.282.1243  
Customer Assistance:  
1.844.LUTRON1  
support@lutron.com  
www.lutron.com/support

**North & South America**  
**Customer Assistance**  
**USA, Canada, Caribbean:**  
1.844.LUTRON1 (1.844.588.7661)  
**Mexico:**  
+1.888.235.2910  
**Central/South America:**  
+1.610.282.6701

### EUROPEAN HEADQUARTERS

**United Kingdom**  
**Lutron EA Limited**  
**125 Finsbury Pavement**  
**4th floor, London EC2A 1NQ**  
**United Kingdom**  
TEL: +44.(0)20.7702.0657  
FAX: +44.(0)20.7480.6899  
FREEPHONE (UK): 0800.282.107  
Technical Support: +44.(0)20.7680.4481  
lutronlondon@lutron.com

### ASIAN HEADQUARTERS

**Singapore**  
**Lutron GL Ltd.**  
**390 Havelock Road**  
**#07-04 King's Centre**  
**Singapore 169662**  
TEL: +65.6220.4666  
FAX: +65.6220.4333  
Technical Support: 800.120.4491  
lutronsea@lutron.com

### Asia Technical Hotlines

Northern China: 10.800.712.1536  
Southern China: 10.800.120.1536  
Hong Kong: 800.901.849  
Indonesia: 001.803.011.3994  
Japan: +81.3.5575.8411  
Macau: 0800.401  
Taiwan: 00.801.137.737  
Thailand: 001.800.120.665853  
Other Countries: +65.6220.4666