

myRoom Palladiom Thermostat Integration to Daikin VRV Systems via Telnet

This document provides an overview of the functionality with the Palladiom thermostat in the myRoom system when integrating with Daikin VRV system via a Telnet connection.

Note: This solution is only available in select regions. Contact Daikin to confirm the availability of the VRV controller and interface adapter. See the “Daikin Hardware and Software” section for model numbers.

Lutron Hardware and Software

Hardware Model Numbers:

- myRoom Processor: GCU-HOSP or GCU-HOSP-1, at least one per room.
 - Palladiom Thermostat: MWP-T-OHW-XXX-A (“XXX” designates the finish), at least one per room. One thermostat controls one HVAC zone. Maximum of 6 HVAC zones per rentable guestroom.
- Note:** A fan coil unit controller (SMC53-MYRM or SMC55-MYRM) is not required for this application.

Software Version:

- myRoom Software: Version 3.3.275 or later

Firmware Version:

- Palladiom Thermostat: Version 4.18 or later

Daikin Hardware and Software

Pacific Asia, Oceania, and Latin America Regions

Daikin Standalone VRV System

Hardware Model Numbers:

- VRV Controller: SVMPS4, at least one per rentable guestroom.
- Interface Adaptor: DTA116A51(Asia, Oceania, India and Latin America regions). One per rentable guestroom.

Compatible with:

- All Daikin VRV systems

Software Version:

- SVMPS4 Version 1.0.0 or later

Daikin Centralized VRV System

Hardware Model Numbers:

- VRV Controller: SVMPS4, at least one per rentable guestroom.
- Interface Adaptor: SVMPC1 + DTA116A51: Asia, Oceania, India and Latin America regions. One per rentable guestroom.

Compatible with:

- All Daikin VRV systems

Software Version:

- SVMPS4 Version 1.0.0 or later
- SVMPC1 Version 2.1.17 or later

Daikin Hardware and Software for China

Hardware Model Numbers:

- VRV controller: KanonBus KCC or KCC-NEW. One per DTA interface adaptor.
- Interface Adapter: DTA116A621. One per up to 64 Daikin indoor units.

Compatible with:

- All Daikin VRV systems

Software Version:

- KCC 4.81 or later

Design Overview

Note that the design below states the SVMPS4 is used. For China, the KanonBus interface is used in place of the SVMPS4.

1. **The current room temperature used to control the Daikin VRV system must come from the Daikin unit's return air sensor, which should be included with the Daikin indoor unit. The temperature sensor on the Palladiom thermostat is disabled for this integration.**
2. The Lutron myRoom system will have a dedicated Guestroom Control Unit (GCU) processor for each room.
 - a. Maximum of 2 GCU processors per room.
3. Each GCU processor will be assigned with a static IP address.
 - a. IP Addresses to be provided by the hotel IT team.
4. Each Daikin HVAC zone requires one Palladiom thermostat.
 - a. See the Lutron Residential and Commercial Systems Rules (P/N 369821) on www.lutron.com for maximum number of primary thermostats per rentable guestroom.
5. Integration IDs for the HVAC zones will be assigned by Lutron or the Hospitality Technology Integrator (HTI). One ID is required per Daikin HVAC zone.
6. Lutron's HTI will generate and submit the following information to Daikin:
 - a. Integration ID of each HVAC zone
 - b. GCU processor IP address assignments
 - c. Telnet login credentials for each processor
7. Daikin will establish Telnet connections with each GCU processor to monitor the Lutron Palladiom thermostats' operation within the room.
 - a. One SVMPS4 (VRV Controller – by Daikin) is allowed per rentable guestroom.

Design Overview (continued)

8. The current room temperature measured by the Daikin return air sensor can be displayed on Lutron's Palladiom thermostat through a Lutron integration protocol command (if displaying the current room temperature on the thermostat is desired).
 - a. Default configuration: The display is set to show only the Setpoint.
9. Dehumidification using the Palladiom thermostat solution is not available with this integration. The Palladiom thermostat only sends the temperature setpoint, fan mode, "Auto/Off" modes.
10. Daikin will ensure the Telnet connection is 'live'. In the event there is a Telnet connection fail, Daikin must re-establish the connection. Examples of connection failures include:
 - a. Power recycles to system
 - b. Time-out and system log-off on either system
11. If any additional HVAC features are required, such as dehumidification, please contact Daikin to ensure the additional features are included in the SVMPS4 integration unit.

System Architecture

The below diagrams outline the system architectures. Note that China uses the KanonBus KCC interface, rather than the SVMPS4, as well as the DTA116A21.

Standalone Daikin VRV System

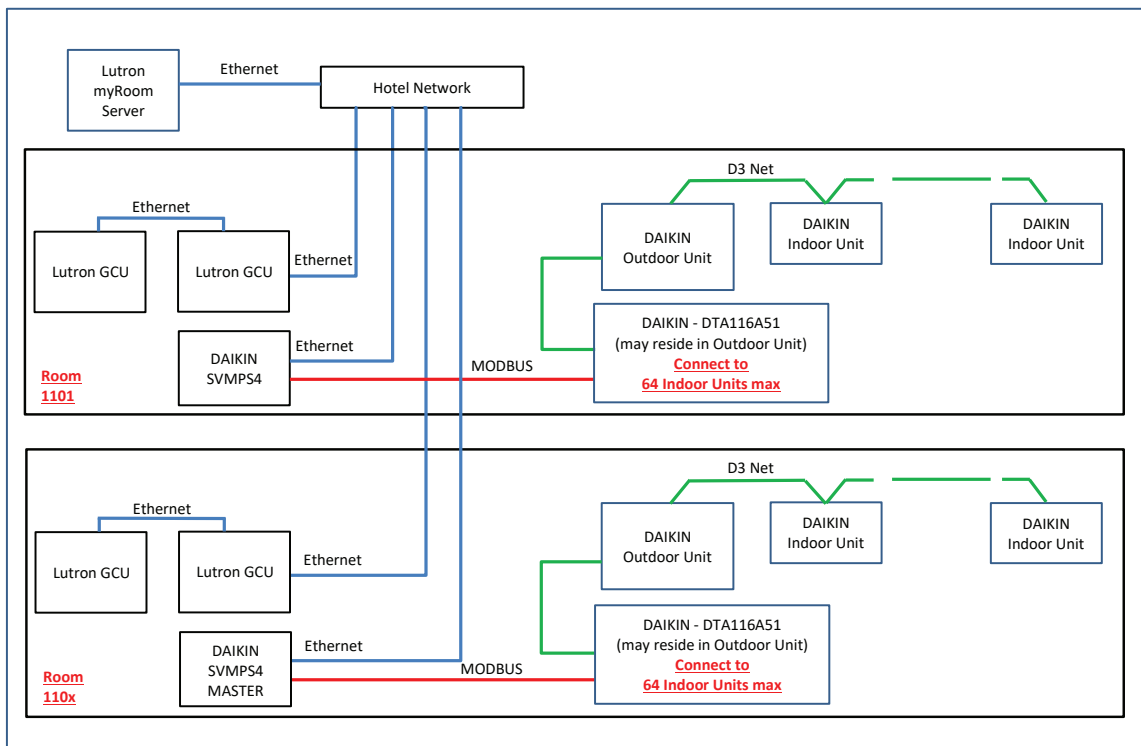

System Architecture (continued)

Centralized Daikin VRV System

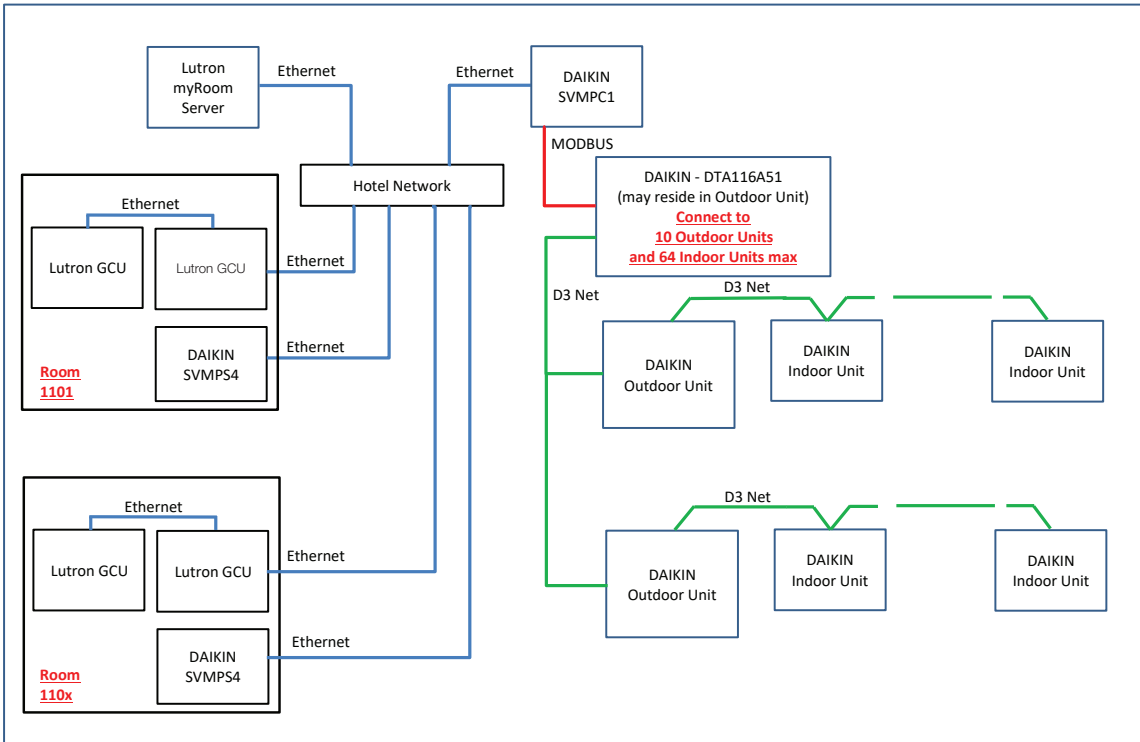

User Interface

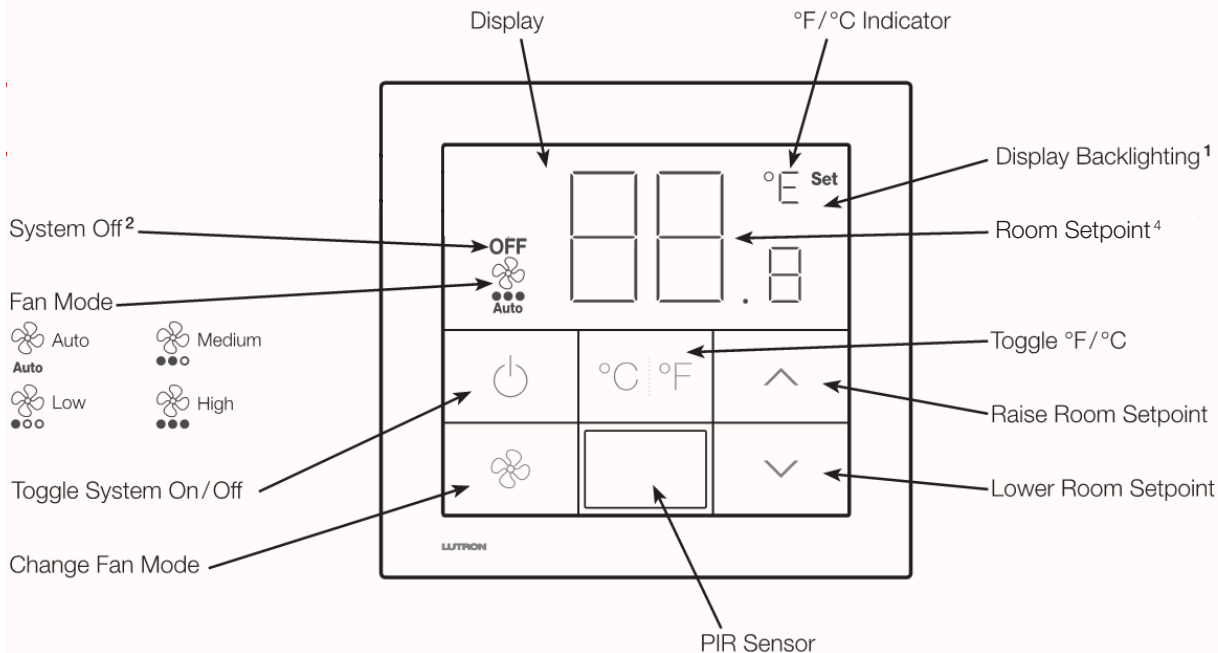

Design Limitations

- No icons will be displayed regarding heating or cooling status (flame or snowflake).
- The temperature display will be the setpoint by default.
 - Displaying the room temperature is available as a configuration during commissioning.
 - To display the current (room) temperature, Daikin will have to send the measured return air temperature via Telnet to the GCU processor.
- HVAC energy reports in myRoom Vue, such as the calls for heat or cool and current fan state, are not available in the graphs.
- Zone temperature shown on the HVAC tile in myRoom Vue must come from the Daikin indoor unit (IDU) return air temperature sensor.

Order of Operations

- A guest can control the room's HVAC using the Lutron Palladiom thermostat via button presses.
- Daikin monitors the HVAC actions via Telnet using Lutron's Integration Protocol.
 - See HVAC: Command Summary section in Lutron's integration protocol guide (P/N 040249) at <https://www.lutron.com/TechnicalDocumentLibrary/040249.pdf>
- The VRV control logic is based on the Setpoint, Fan Speed, and Operating Mode provided by the Lutron Palladiom thermostat.

Telnet Commands

For a list of HVAC zone commands, see HVAC Zone Command section in Lutron's integration protocol guide (P/N 040249) at <https://www.lutron.com/TechnicalDocumentLibrary/040249.pdf>

Lutron, Palladiom, and myRoom are trademarks or registered trademarks of Lutron Electronics Co., Inc. in the US and/or other countries. All other product names, logos, and brands are property of their respective owners.

Lutron Contact Numbers

WORLD HEADQUARTERS

USA
Lutron Electronics Co., Inc.
7200 Suter Road
Coopersburg, PA 18036-1299
TEL: +1.610.282.3800
FAX: +1.610.282.1243
support@lutron.com
www.lutron.com/support

**North & South America
Customer Assistance**
USA, Canada, Caribbean:
1.844.LUTRON1 (1.844.588.7661)
Mexico:
+1.888.235.2910
Central/South America:
+1.610.282.6701

UK AND EUROPE:

Lutron EA Limited
125 Finsbury Pavement
4th floor, London EC2A 1NQ
United Kingdom
TEL: +44.(0)20.7702.0657
FAX: +44.(0)20.7480.6899
FREEPHONE (UK): 0800.282.107
Technical Support: +44.(0)20.7680.4481
lutronlondon@lutron.com

ASIA:

Lutron GL Ltd.
390 Havelock Road
#07-04 King's Centre
Singapore 169662
TEL: +65.6220.4666
FAX: +65.6220.4333
Technical Support: 800.120.4491
lutronsea@lutron.com

Asia Technical Hotlines

Northern China: 10.800.712.1536
Southern China: 10.800.120.1536
Hong Kong: 800.901.849
Indonesia: 001.803.011.3994
Japan: +81.3.5575.8411
Macau: 0800.401
Taiwan: 00.801.137.737
Thailand: 001.800.120.665853
Other Countries: +65.6220.4666