

ROLLER 100/150/300

WALL MOUNT SHADE

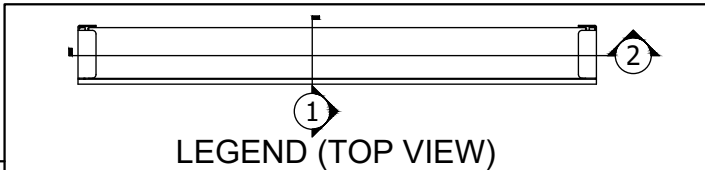
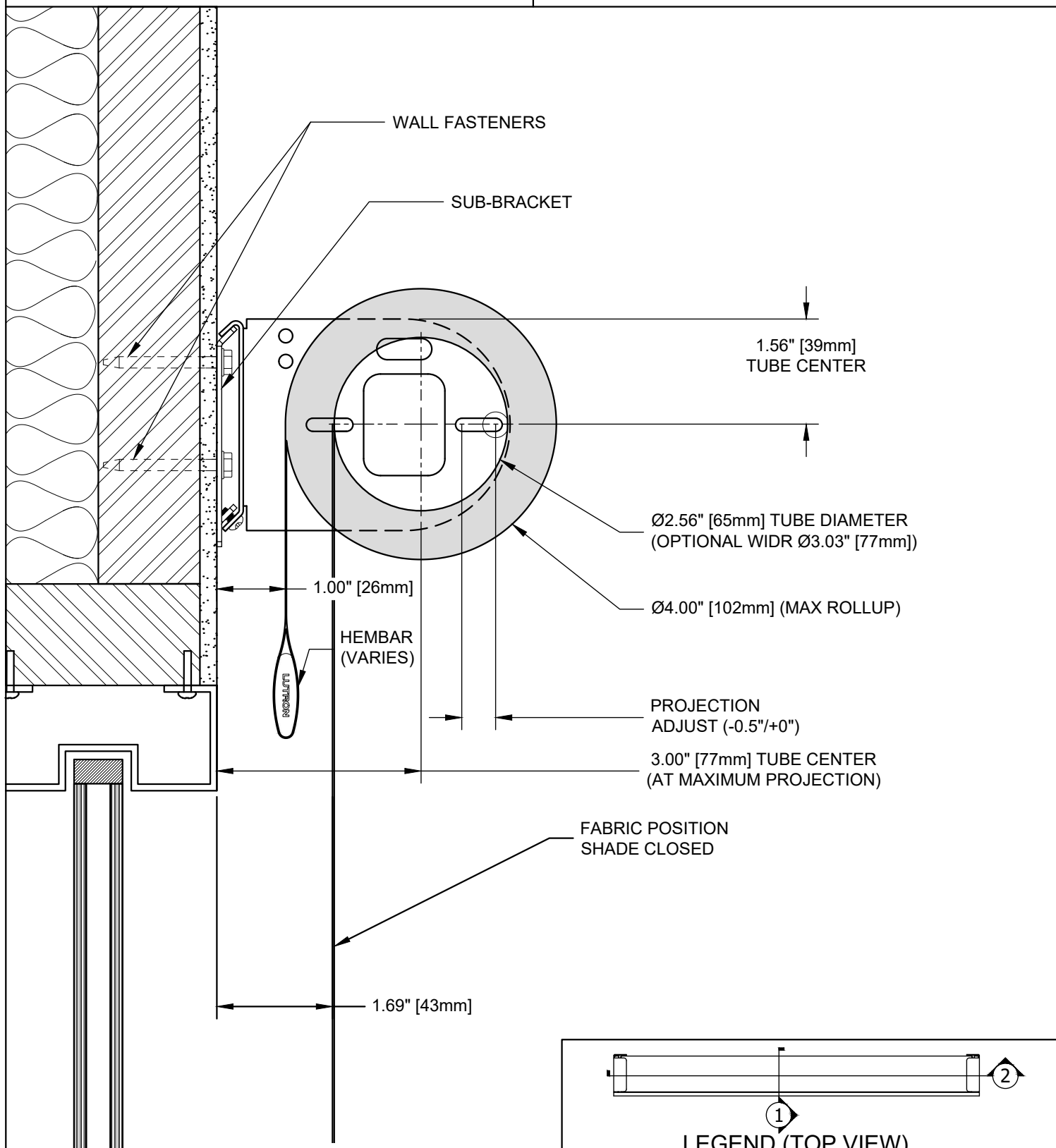

LEGEND (TOP VIEW)

SHADE INSTALLED AS PROVIDED BY FACTORY WILL HAVE ALL NECESSARY CLEARANCES FOR PROPER OPERATION. IF ADJUSTMENT FEATURES ARE UTILIZED, IT IS THE RESPONSIBILITY OF THE INSTALLER TO ENSURE PROPER CLEARANCES ARE MAINTAINED. NOT ALL ADJUSTMENTS ARE AVAILABLE AT MAXIMUM ROLL Ø.

ROLLER 100/150/300		085383
SCALE: 1/2	VIEW: 1	REVISION: B