

ROLLER 100/150/300

R100 - HIGH ANGLED COUPLED

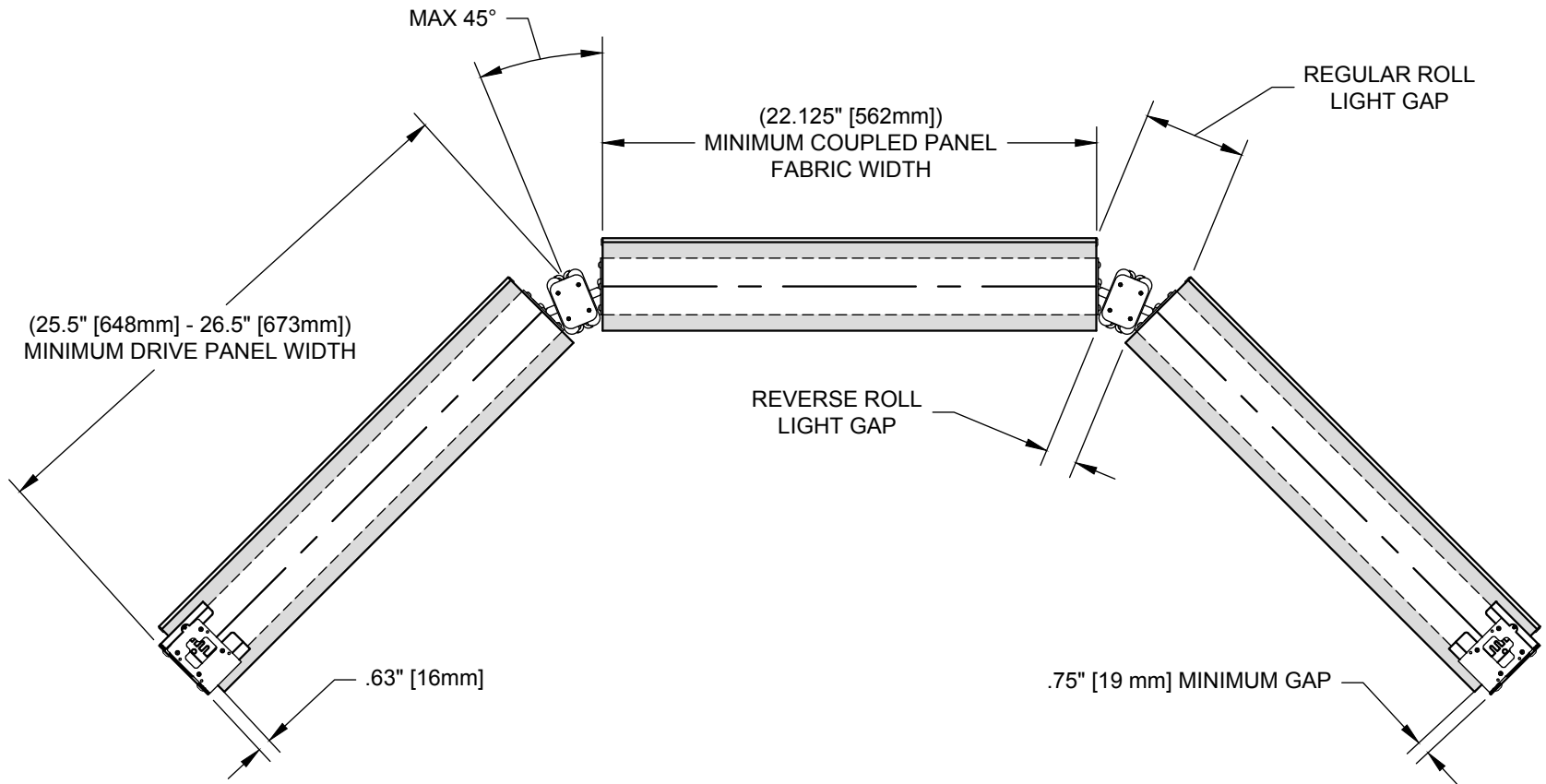

SHADE INSTALLED AS PROVIDED BY FACTORY WILL HAVE ALL NECESSARY CLEARANCES FOR PROPER OPERATION. IF ADJUSTMENT FEATURES ARE UTILIZED, IT IS THE RESPONSIBILITY OF THE INSTALLER TO ENSURE PROPER CLEARANCES ARE MAINTAINED. NOT ALL ADJUSTMENTS ARE AVAILABLE AT MAXIMUM ROLL Ø.

ROLLER 100/150/300

085417

SCALE: 1/8

VIEW: PLAN

REVISION: A

 **LUTRON** Lutron Electronics Co., Inc.  
7200 Suter Road | Coopersburg, PA 18036 | USA  
1(800) 446-1503 | Fax: (610) 282-7439  
<http://www.lutron.com>

**PLAN VIEW**