

PALLADIOM WIRE-FREE SHADE

BUTT AND PASS TYPICAL DETAILS

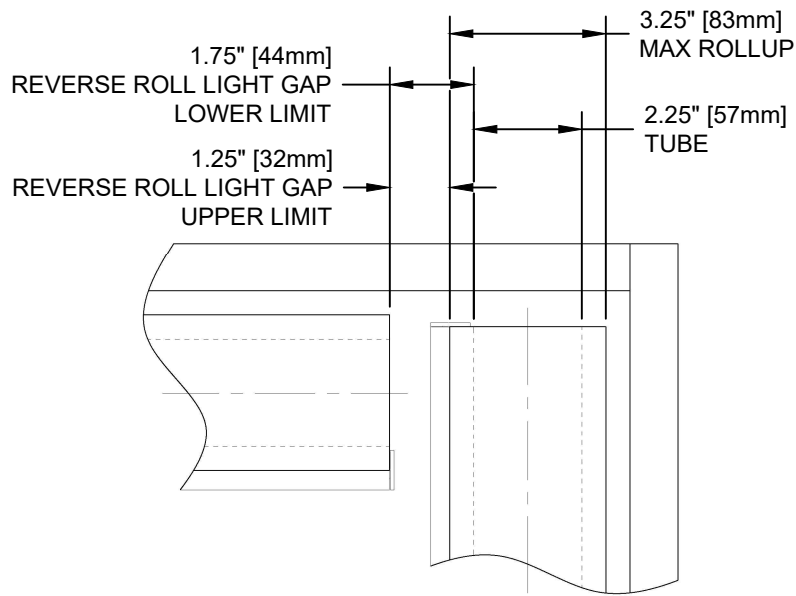

IDLERS MUST BE IN THE CORNER.
NO ROOM FOR BATTERY CHANGE.

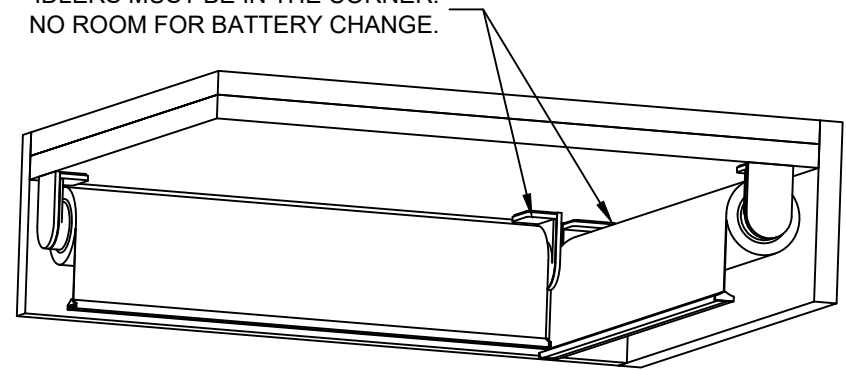

SCALE: 1/8

CEILING BRACKET SHOWN

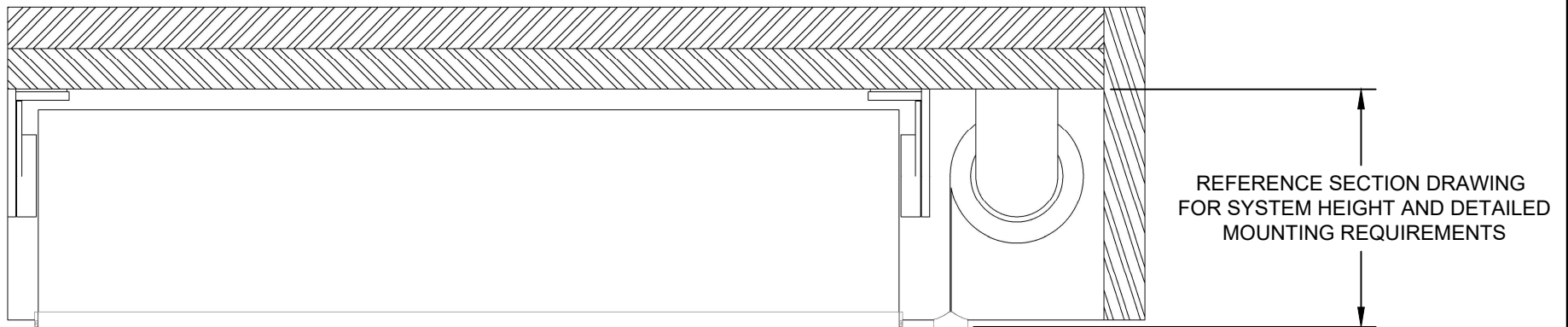

SHADE INSTALLED AS PROVIDED BY FACTORY WILL HAVE ALL NECESSARY CLEARANCES FOR PROPER OPERATION. IT IS THE RESPONSIBILITY OF THE MASTER TECHNICIAN TO ENSURE PROPER CLEARANCES ARE MAINTAINED AFTER INSTALLATION.

PWF SHADE BUTT AND PASS INSTALLATION

085736

SCALE: 1/4

PAGE: 1

REVISION: A

PALLADIOM WIRE-FREE SHADE

BUTT AND PASS TYPICAL DETAILS

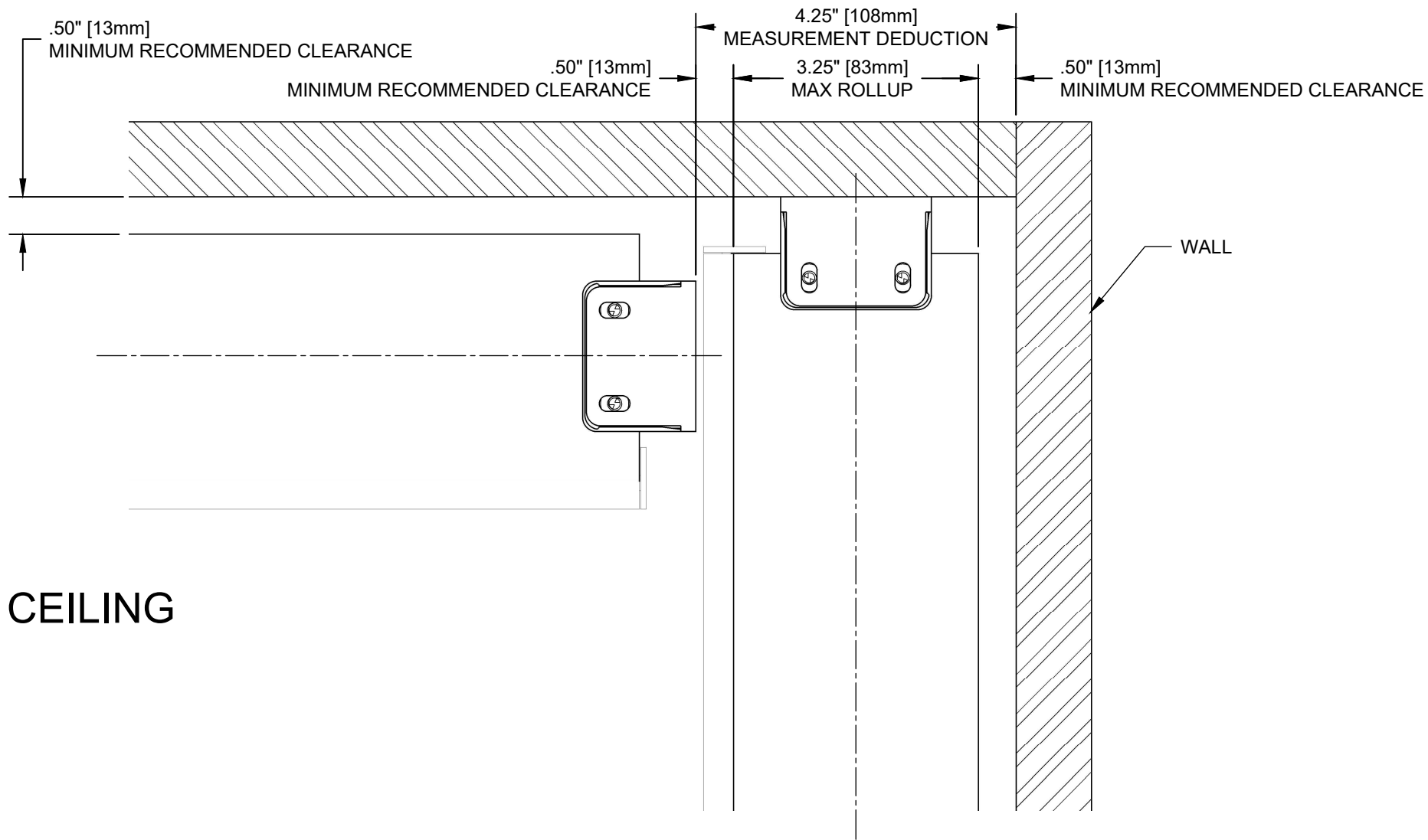

CEILING

WALL

SHADE INSTALLED AS PROVIDED BY FACTORY WILL HAVE ALL NECESSARY CLEARANCES FOR PROPER OPERATION. IT IS THE RESPONSIBILITY OF THE MASTER TECHNICIAN TO ENSURE PROPER CLEARANCES ARE MAINTAINED AFTER INSTALLATION.

PWF SHADE BUTT AND PASS INSTALLATION

085736

SCALE: 1/2

PAGE: 2

REVISION: A