

CLERESTORY

CLERESTORY SHADE IN A 7" X 7" POCKET

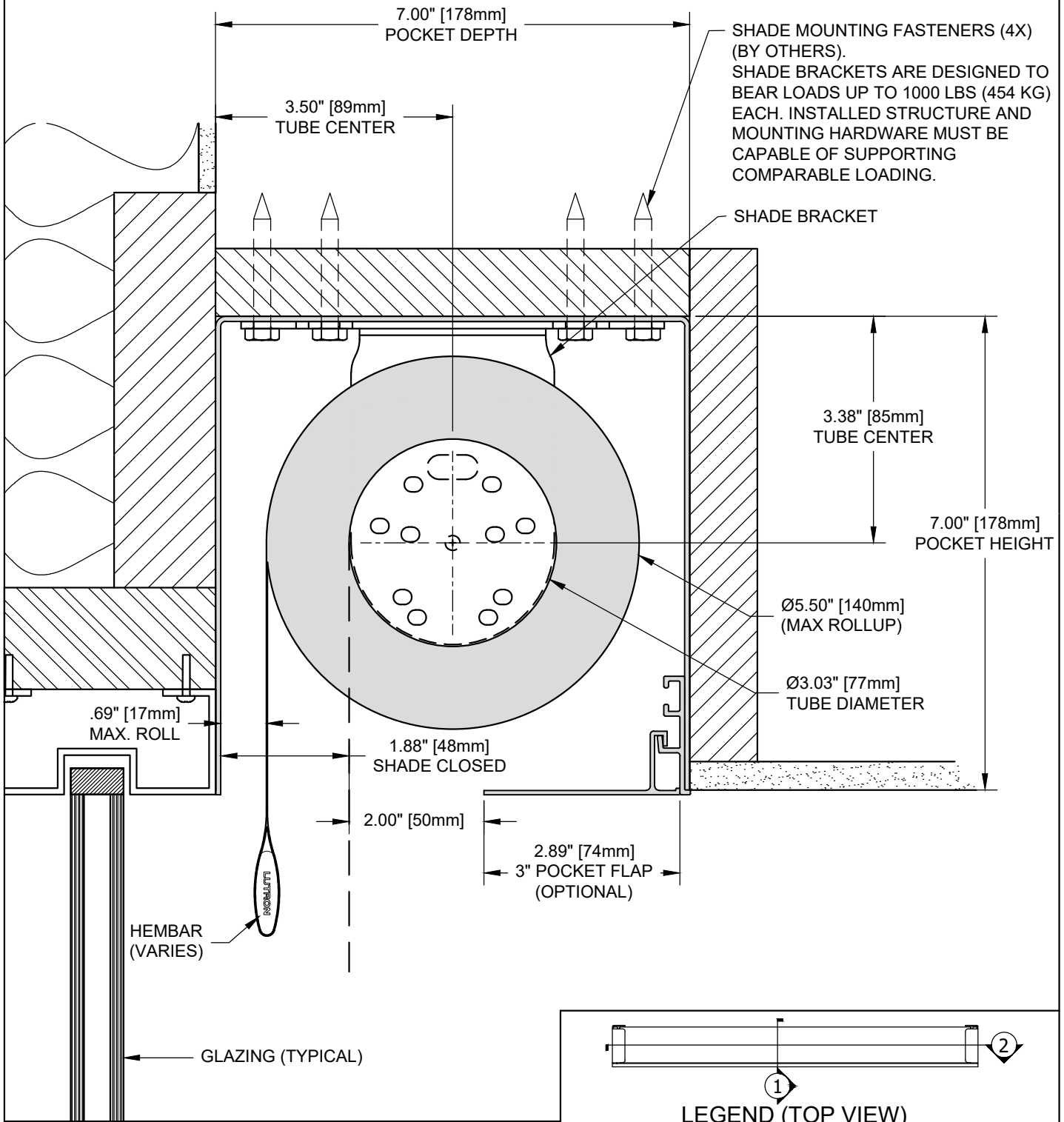

SHADE INSTALLED AS PROVIDED BY FACTORY WILL HAVE ALL NECESSARY CLEARANCES FOR PROPER OPERATION. IF ADJUSTMENT FEATURES ARE UTILIZED, IT IS THE RESPONSIBILITY OF THE INSTALLER TO ENSURE PROPER CLEARANCES ARE MAINTAINED. NOT ALL ADJUSTMENTS ARE AVAILABLE AT MAXIMUM ROLL Ø.

CLERESTORY		085780
SCALE: 1/2	VIEW: 1	REVISION: D