

TRIATHLON SELECT TYPE A SHADE

JAMB MOUNT SHADE

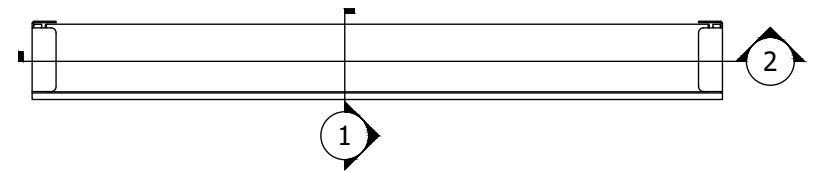
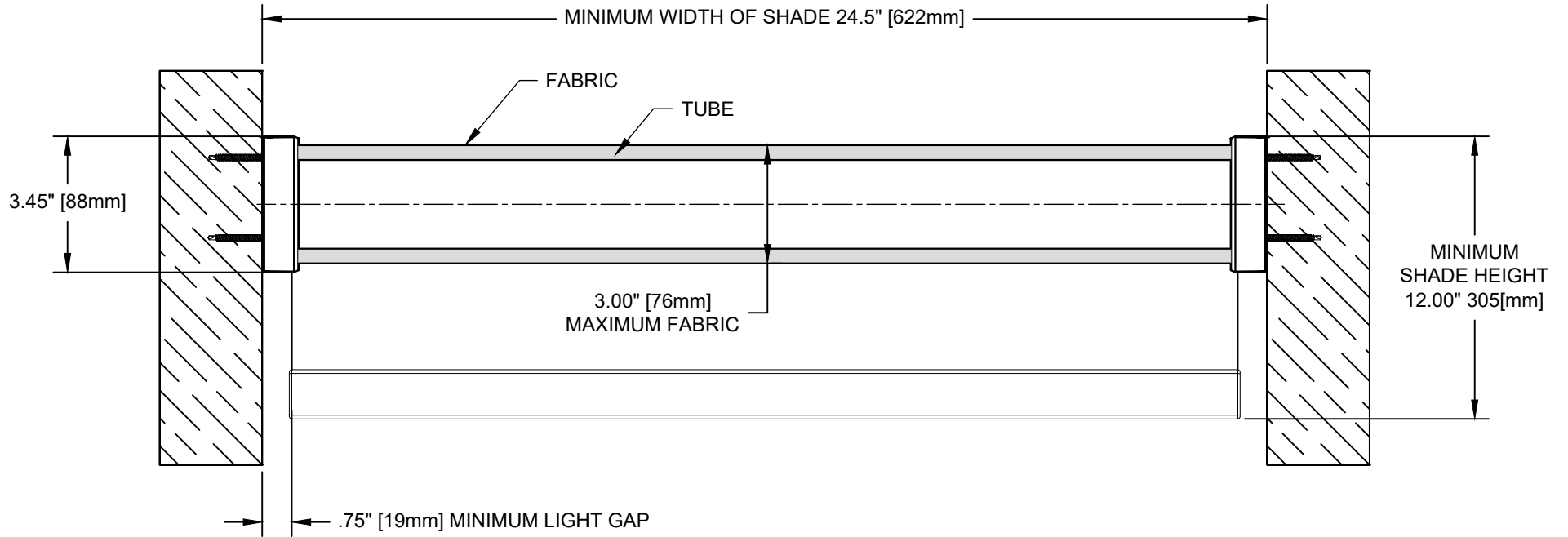

LEGEND (TOP VIEW)

SHADE INSTALLED AS PROVIDED BY FACTORY WILL HAVE ALL NECESSARY CLEARANCES FOR PROPER OPERATION. IT IS THE RESPONSIBILITY OF THE MASTER TECHNICIAN TO ENSURE PROPER CLEARANCES ARE MAINTAINED AFTER INSTALLATION.

TRIATHLON SELECT

085798

SCALE: 1/4

VIEW: 2

REVISION: A



Lutron Electronics Co., Inc.
7200 Suter Road | Coopersburg, PA 18036 | USA
1(800) 446-1503 | Fax: (610) 282-7439
<http://www.lutron.com>

ELEVATION VIEW

TRIATHLON SELECT TYPE B SHADE

JAMB MOUNT SHADE

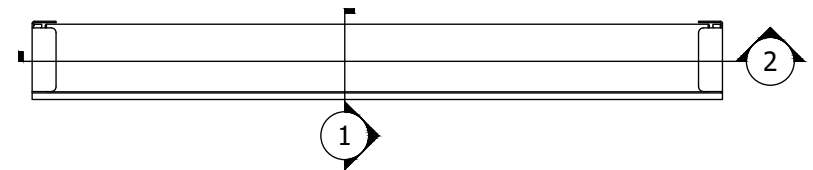
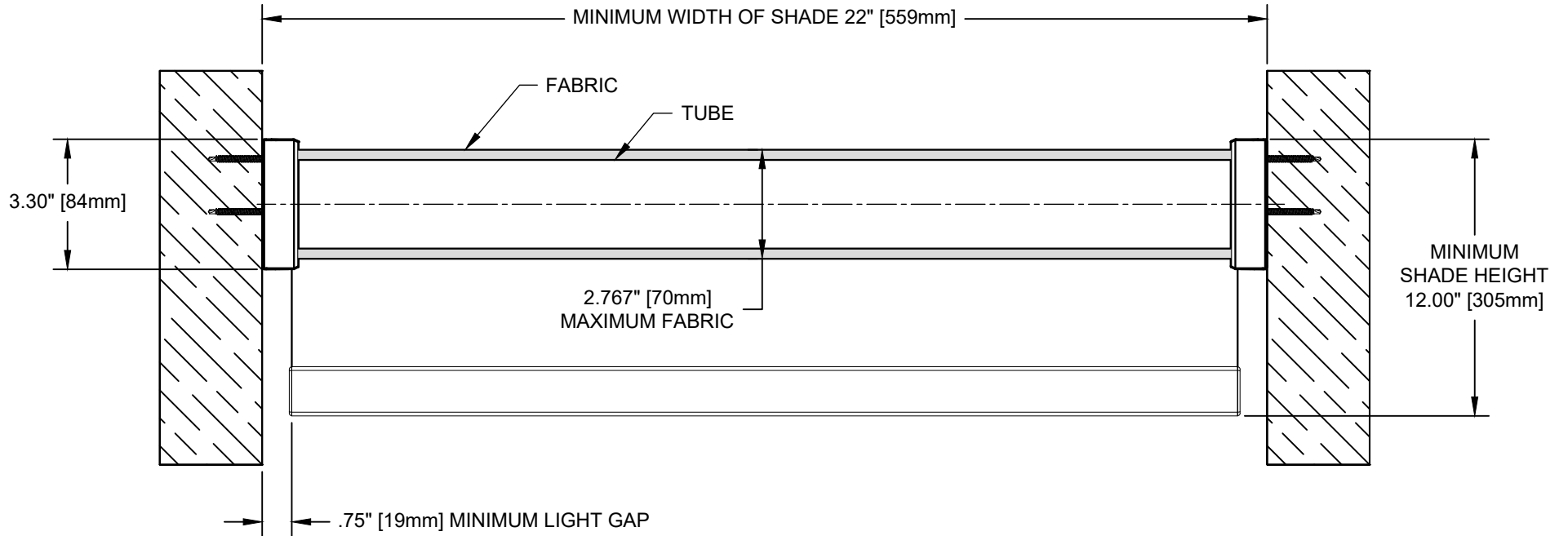

LEGEND (TOP VIEW)

SHADE INSTALLED AS PROVIDED BY FACTORY WILL HAVE ALL NECESSARY CLEARANCES FOR PROPER OPERATION. IT IS THE RESPONSIBILITY OF THE MASTER TECHNICIAN TO ENSURE PROPER CLEARANCES ARE MAINTAINED AFTER INSTALLATION.

TRIATHLON SELECT

085798

SCALE: 1/4

VIEW: 2

REVISION: A



Lutron Electronics Co., Inc.
7200 Suter Road | Coopersburg, PA 18036 | USA
1(800) 446-1503 | Fax: (610) 282-7439
<http://www.lutron.com>

ELEVATION VIEW