

TRIATHLON SELECT TYPE A SHADE

CEILING MOUNT SHADE

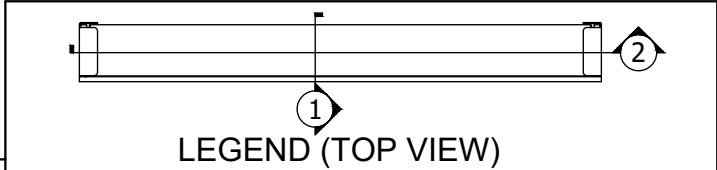
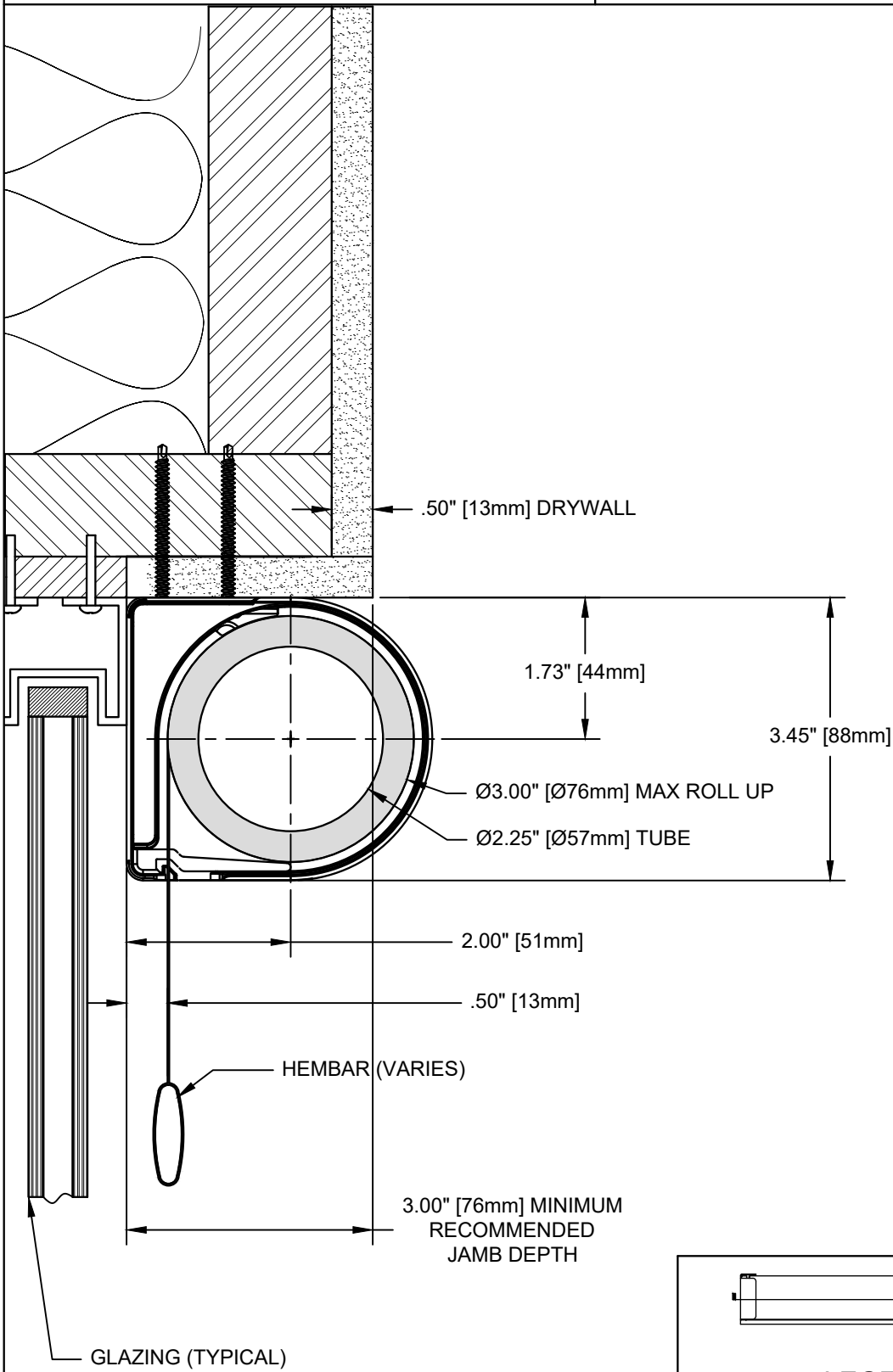

SHADE INSTALLED AS PROVIDED BY FACTORY WILL HAVE ALL NECESSARY CLEARANCES FOR PROPER OPERATION. IT IS THE RESPONSIBILITY OF THE MASTER TECHNICIAN TO ENSURE PROPER CLEARANCES ARE MAINTAINED AFTER INSTALLATION.

TRIATHLON SELECT	085799
SCALE: 1/2	VIEW: 1 REVISION: A

SECTION VIEW

TRIATHLON SELECT TYPE B SHADE

CEILING MOUNT SHADE

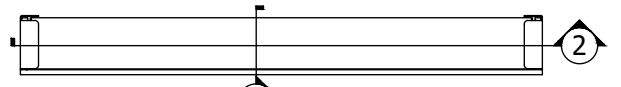
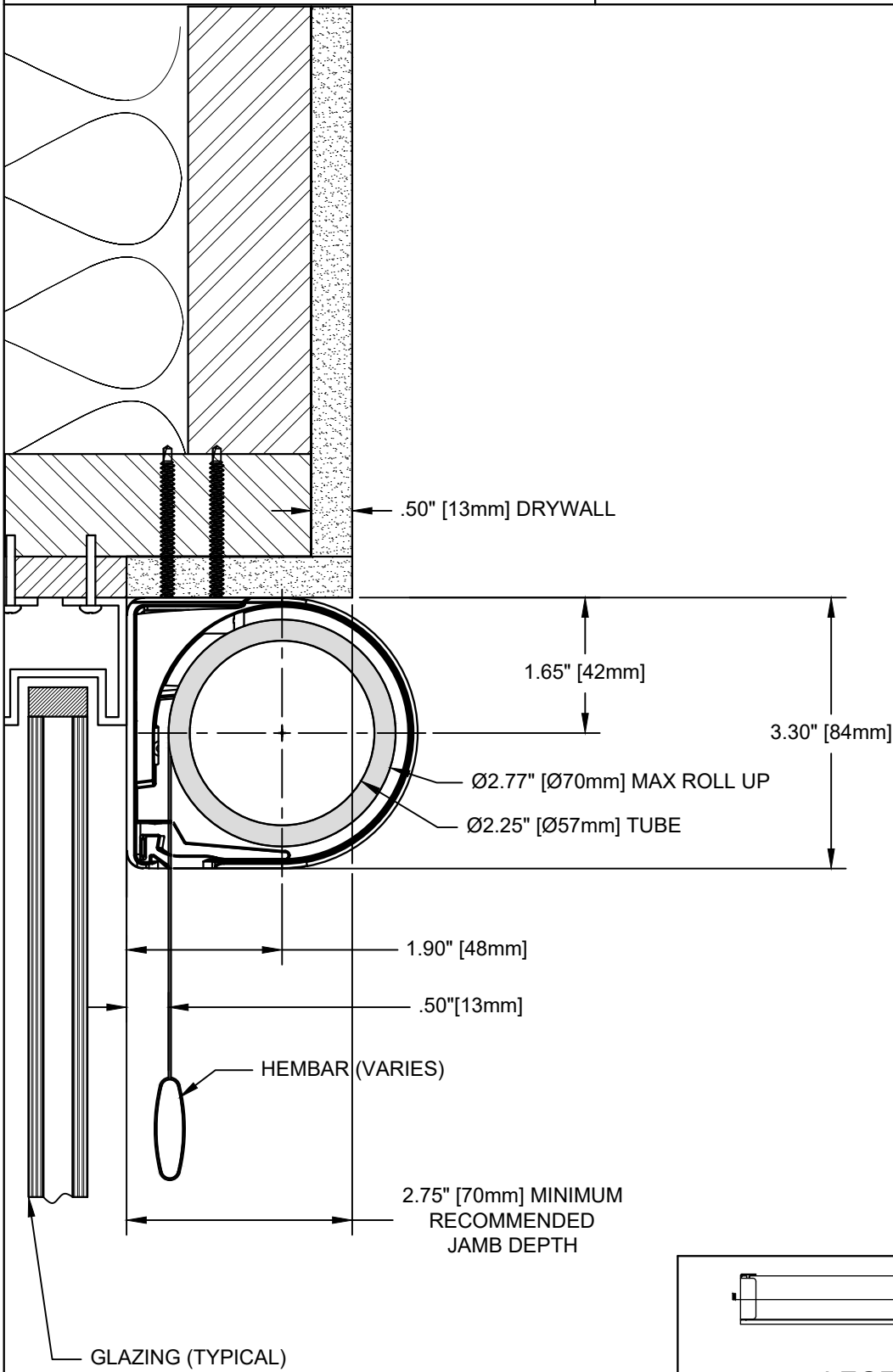

LEGEND (TOP VIEW)

SHADE INSTALLED AS PROVIDED BY FACTORY WILL HAVE ALL NECESSARY CLEARANCES FOR PROPER OPERATION. IT IS THE RESPONSIBILITY OF THE MASTER TECHNICIAN TO ENSURE PROPER CLEARANCES ARE MAINTAINED AFTER INSTALLATION.

TRIATHLON SELECT

085799

SCALE: 1/2

VIEW: 1

REVISION: A



Lutron Electronics Co., Inc.
7200 Suter Road | Coopersburg, PA 18036 | USA
(800) 446-1503 | Fax: (610) 282-7439
<http://www.lutron.com>

SECTION VIEW