

TRIATHLON SELECT TYPE A SHADE

JAMB MOUNT SHADE

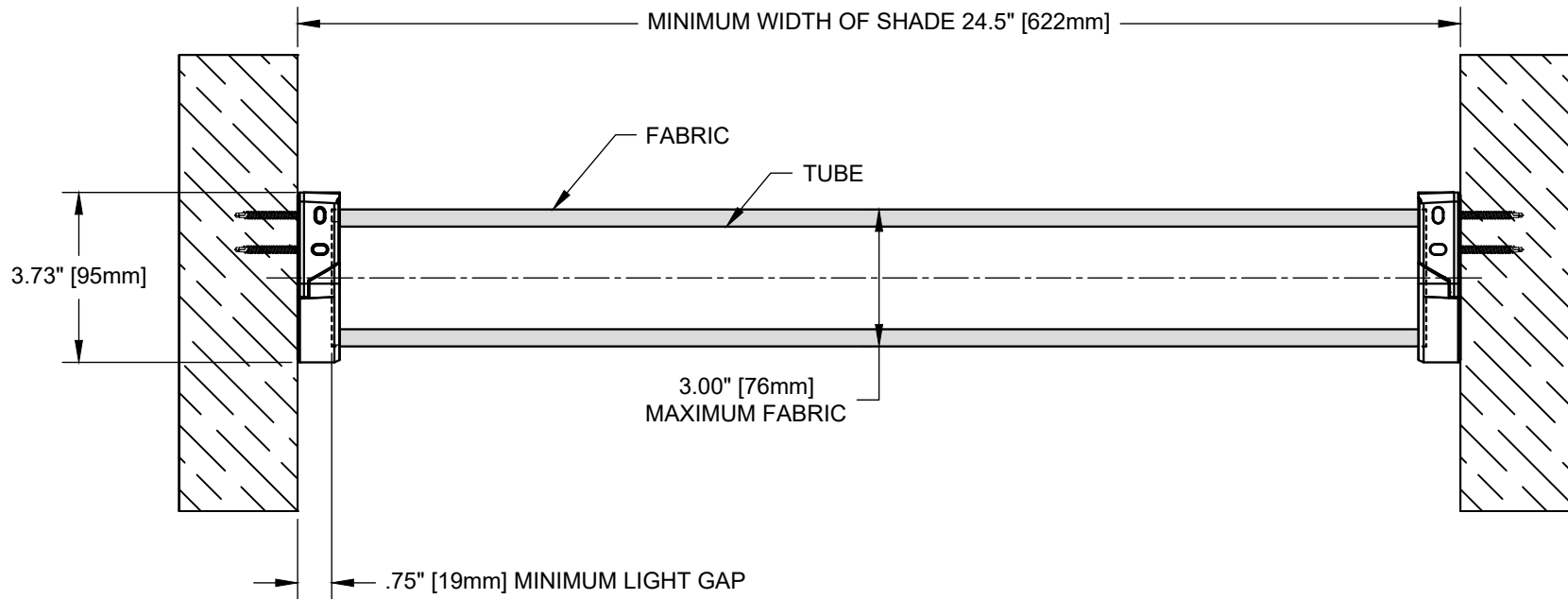

SHADE INSTALLED AS PROVIDED BY FACTORY WILL HAVE ALL NECESSARY CLEARANCES FOR PROPER OPERATION. IT IS THE RESPONSIBILITY OF THE MASTER TECHNICIAN TO ENSURE PROPER CLEARANCES ARE MAINTAINED AFTER INSTALLATION.

TRIATHLON SELECT

085800

SCALE: 1/4

VIEW: PLAN

REVISION: A



Lutron Electronics Co., Inc.
7200 Suter Road | Coopersburg, PA 18036 | USA
1(800) 446-1503 | Fax: (610) 282-7439
<http://www.lutron.com>

PLAN VIEW

TRIATHLON SELECT TYPE B SHADE

JAMB MOUNT SHADE

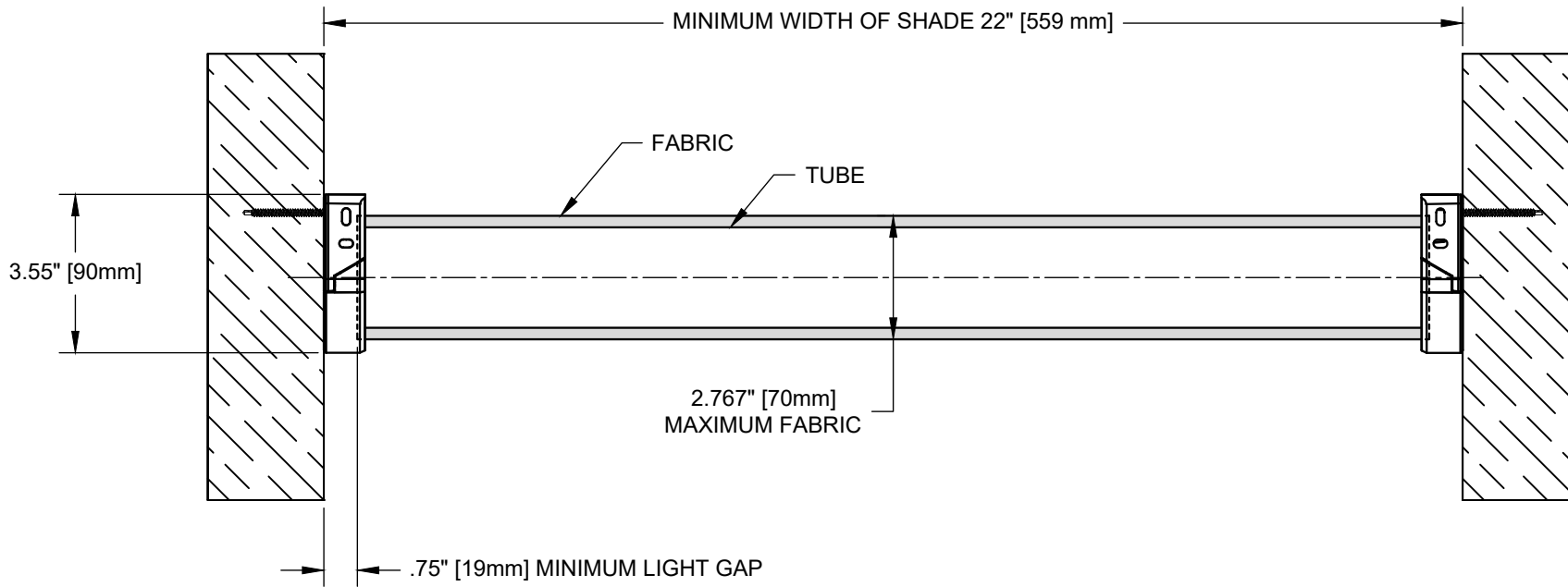

SHADE INSTALLED AS PROVIDED BY FACTORY WILL HAVE ALL NECESSARY CLEARANCES FOR PROPER OPERATION. IT IS THE RESPONSIBILITY OF THE MASTER TECHNICIAN TO ENSURE PROPER CLEARANCES ARE MAINTAINED AFTER INSTALLATION.

TRIATHLON SELECT

085800

SCALE: 1/4

VIEW: PLAN

REVISION: A