

### Serena Open Roll Shades

Lutron smart roller shades are ideal for exposed applications. These shades utilize a completely wire-free, quiet drive, powered by readily available D-cell alkaline batteries. Lutron smart roller shades can be installed virtually anywhere, providing privacy and light control at the touch of a button.

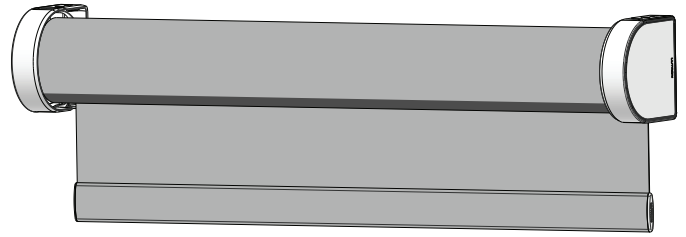

#### Features

- 2 year battery performance typical, using (5) D-cell alkaline batteries
- Quiet operation: 44 dBa measured 3 ft (0.9 m) from the drive
- Precise drive is capable of stopping at 0.125 in (3 mm) intervals throughout the entire travel of the shade
- Shades available in:
  - Widths from 24.5 in (62.23 cm) to 108 in (274.32 cm)
  - Heights from 12 in (30.48 cm) to 120 in (304.8 cm)
- Easy installation and maintenance
- Built-in wireless communication using Clear Connect – Type A RF technology
- Wireless control range: 30 ft (9 m)
- Symmetrical light gaps, as small as 0.75 in (1.90 cm), nominal
- Available with a variety of fabric types including sheer, translucent, and room darkening fabrics with coordinating bracket colors
- Regular roll only
- Left-drive only

<b>Job Name:</b>	<b>Model Numbers:</b>
<b>Job Number:</b>	

## Specifications

### Regulatory

- cULus listed
- FCC (USA)
- IC (Canada)

### Ratings

- Operating voltage: 7.5 V<sub>DC</sub>
- Operating wattage: 4 W
- Torque: 4.0 in-lb (0.45 N•m)
- Speed: 2.5 in/sec (63.5 mm/sec)

### Compatible Controls

- Pico wireless control
- Caséta Smart Hub
- Caséta Smart Hub PRO

### Environment

- Temperature: 32 °F to 104 °F (0 °C to 40 °C)
- For indoor use only
- Relative Humidity: <90% non-condensing

Job Name:	Model Numbers:
Job Number:	

### Dimensions

All measurements shown as: in (cm)

#### Type A

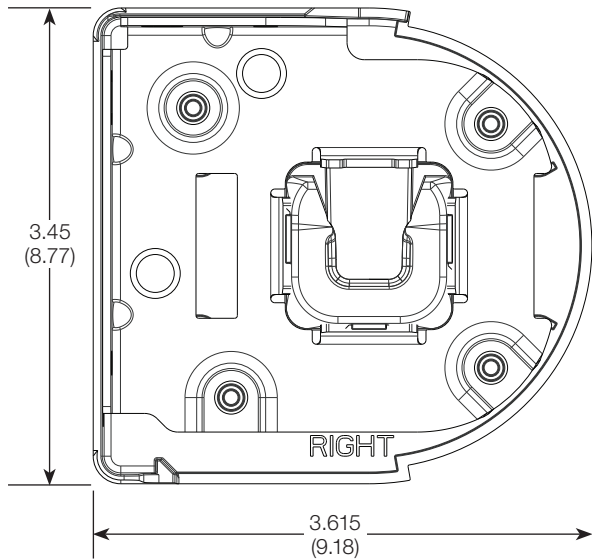

#### Type A

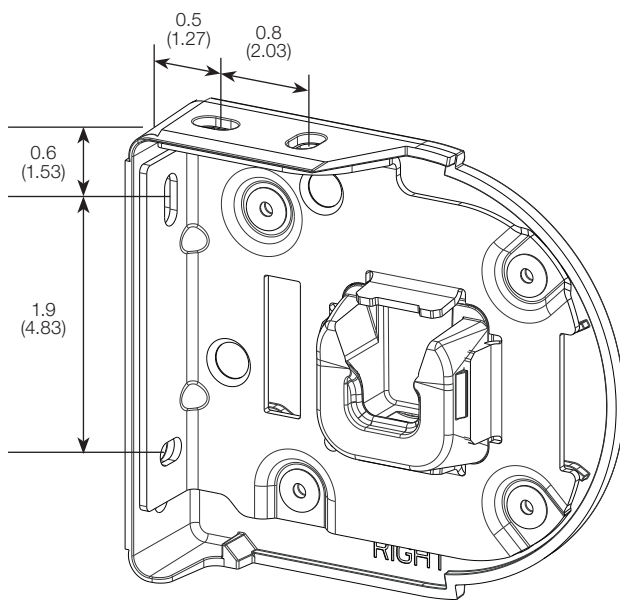

Job Name:	Model Numbers:
Job Number:	

### Ordered Shade Width and Height

All measurements shown as: in (cm)

**Note:** Ordered shade measurements are from the outer faces of the brackets for the width and top of the bracket to the bottom of the hembar for the vertical measurement.

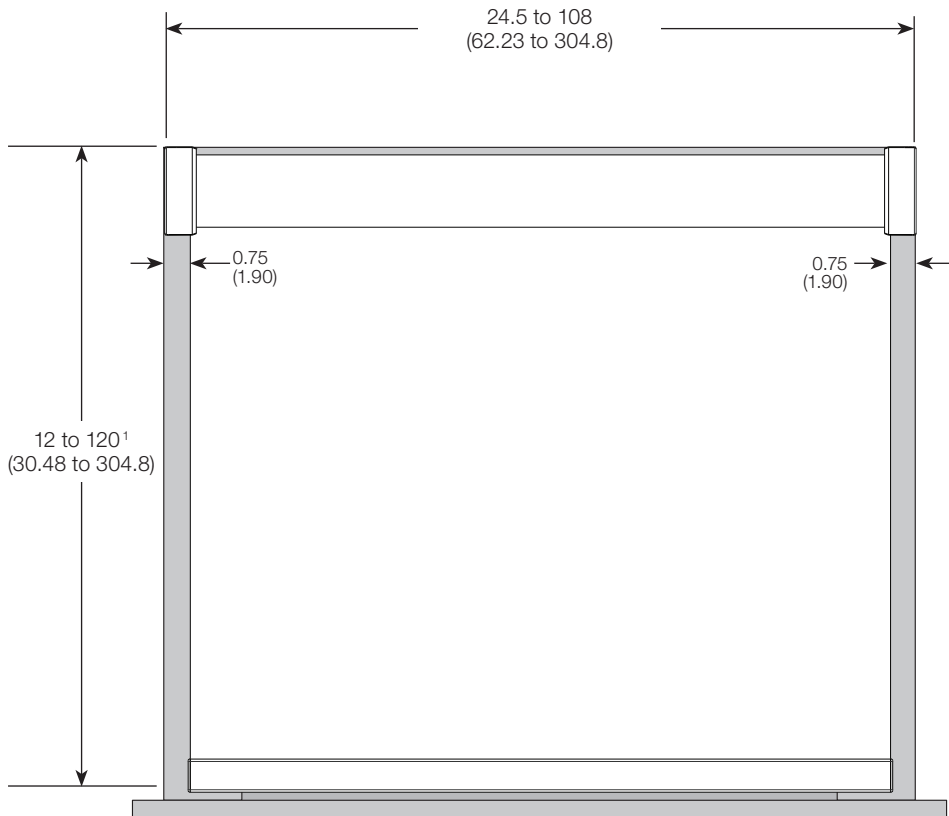

<sup>1</sup> Dependent on fabric selection

Job Name:	Model Numbers:
Job Number:	

### Battery Power

Powered by 1.5 V, D-Cell, alkaline batteries (not included).

Install **NEW** batteries. Do not mix brands or types. A diagram on the battery sleeve indicates correct orientation. Battery life varies with shade size, fabric weight, and daily usage patterns.

To achieve optimal battery life, Lutron recommends batteries from specific manufacturers. Using non-recommended batteries or improper installation will significantly reduce battery life. For the latest on recommended manufacturers as well as other information about optimizing battery life in your Lutron shades, please visit [lutron.com/optimizing-battery-life](http://lutron.com/optimizing-battery-life)

### Battery Access Clearance

The clearances shown below are required for unrestricted battery installation and change access.

**Bracket Mounting Depth:** Access to the battery compartment relies on the “slide-out”, battery access feature of left shade bracket.

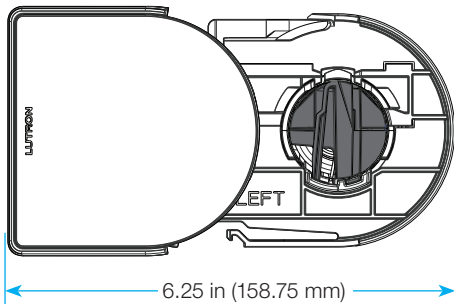

### Battery Sleeve Removal/Insertion:

Batteries are housed in a sleeve that fits inside the EDU. Removal and insertion of the sleeve requires clearance to end walls and other window-adjacent objects or structures.

The quantity of batteries required varies with shade configuration and will be indicated on battery sleeve.

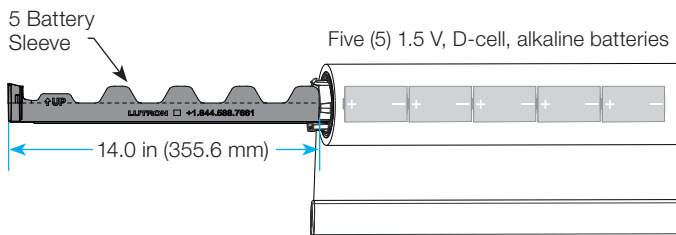

### Close-quarters Installations:

When the installation location does not allow the battery sleeve clearances shown above, the shade must be uninstalled from the brackets to access the battery sleeve. Refer to installation guide for further instructions.

Job Name:	Model Numbers:
Job Number:	

### Mounting Options

Depending on the window dimensions, the shade can be mounted inside the window frame or outside the window frame. Brackets must be installed in the indicated orientation and cannot be rotated.

#### CEILING INSIDE MOUNT OR JAMB INSIDE MOUNT

To fully recess the shade, the window jamb must be at least 3.75 in (95 mm) deep. Installation of the shade relies on the "slide-out" battery access feature of the shade brackets.

To install or remove the shade brackets, an additional clearance of 3.75 in (95 mm) is required in front of the shade.

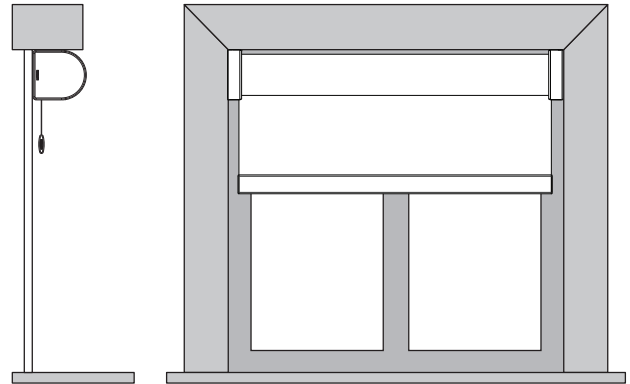

#### CEILING MOUNT

Screws are driven through the top of the bracket into the blocking as shown.

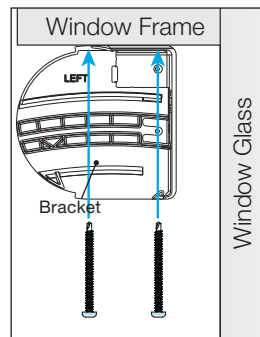
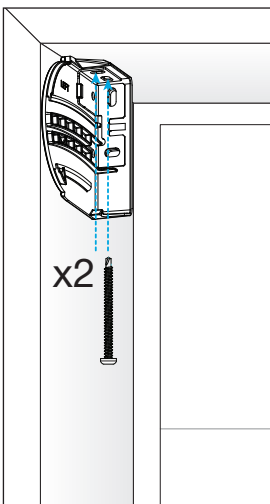

#### JAMB MOUNT

Screws are driven through the side of the bracket into the blocking as shown. It is recommended that holes are drilled through the bracket before mounting. Flat head screws (not provided) are required for jamb mount.

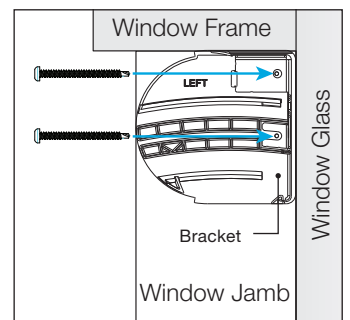
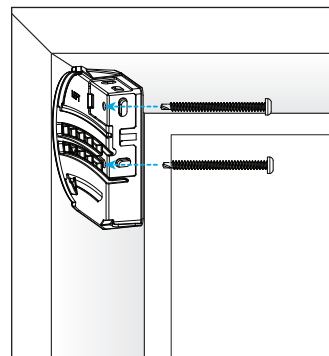

Job Name:	Model Numbers:
Job Number:	

### Mounting Options (continued)

Depending on the window dimensions, the shade can be mounted inside the window frame or outside the window frame. Brackets must be installed in the indicated orientation and cannot be rotated.

#### OUTSIDE MOUNT ON TRIM

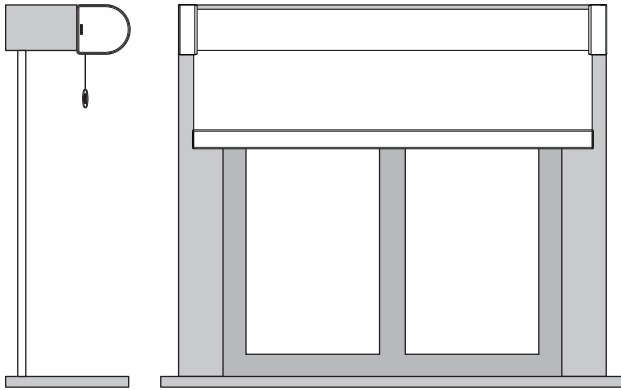

Installation of the shade relies on the "slide-out" battery access feature of the shade brackets. An additional clearance of 3.75 in (95 mm) is required in front of the shade to install or remove the shade brackets.

Screws are driven through the back of the bracket into the blocking as shown.

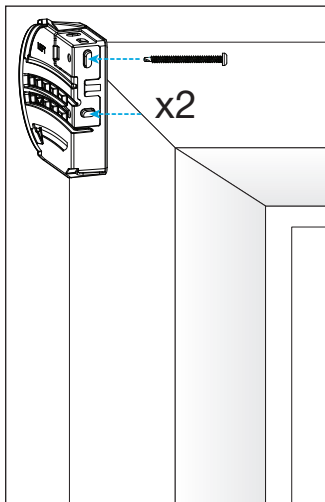

#### OUTSIDE MOUNT ABOVE TRIM

Spacers and longer screws are included when outside mount above trim is indicated. Spacers may also be used to clear window or door handles as needed.\* Spacers provide 1/2 in (12.7 mm) of clearance off of mounting surface. Spacers cannot be stacked.

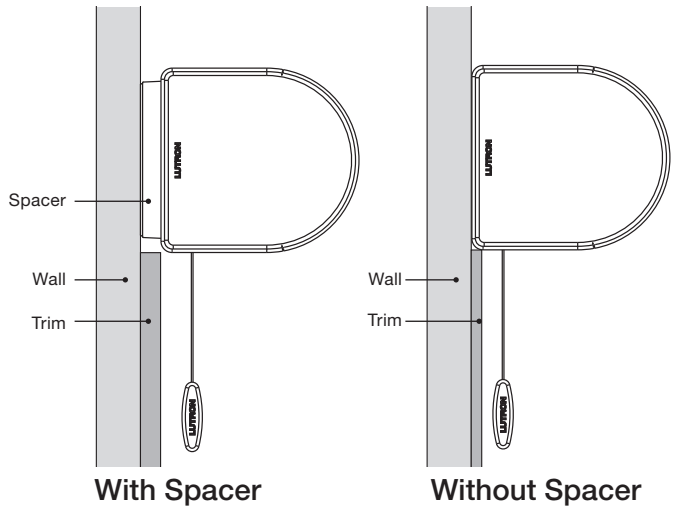
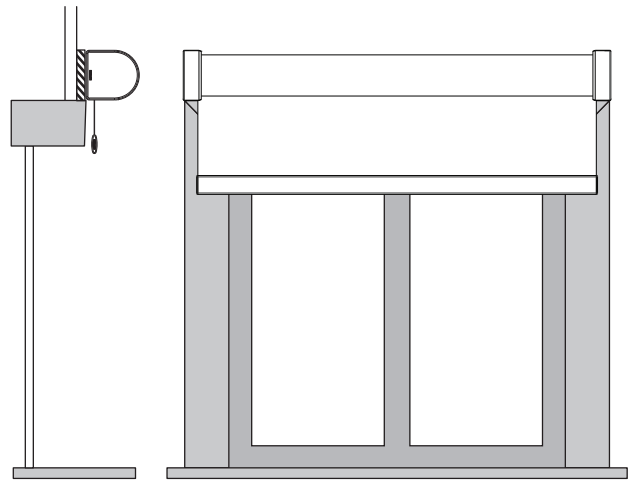

\* Spacer kits included for orders specifying "Outside Mount Above Trim" and can be provided upon request.

Lutron, Caséta, Clear Connect, Pico, Serena, and any related trade dress and logos are trademarks or registered trademarks of Lutron Electronics Co., Inc. in the US and/or other countries.

All other product names, logos, and brands are property of their respective owners.

Job Name:	Model Numbers:
Job Number:	