

# Switching Power Module

The DIN Power Module (DPM) family is a group of modular products for the control of lighting loads. This product is compatible with Lutron HomeWorks QS systems. This document describes the following product:

- LQSE-4S8-120-D: 4-zone power module for switching only.

## Features

- Four switched output zones.
- Adaptive zero-cross switching maximizes relay life.
- Rated for lighting loads as defined by UL® 508, NEMA 410, as well as INC, MLV, and ELV.
- Rated for motor loads of 1/3 HP.
- Includes QS link for seamless connection to a HomeWorks QS system.
- LEDs on the module provide diagnostic information.
- Buttons on module provide override control.
- Manual Override Contact Closure Input (CCI).
- Programmable Contact Closure Output (CCO).
- Power failure memory automatically returns the outputs to the levels they were set to prior to a power outage.

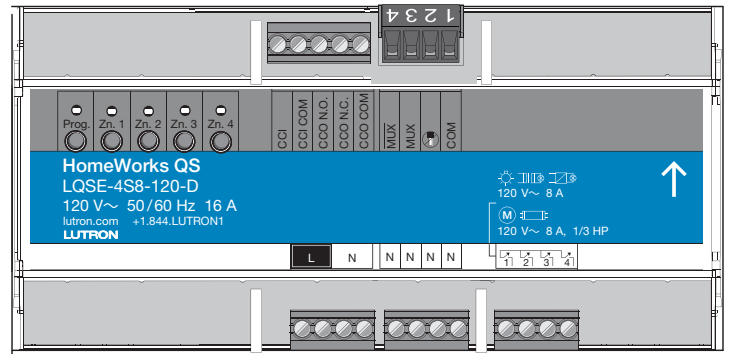

LQSE-4S8-120-D

## System Example

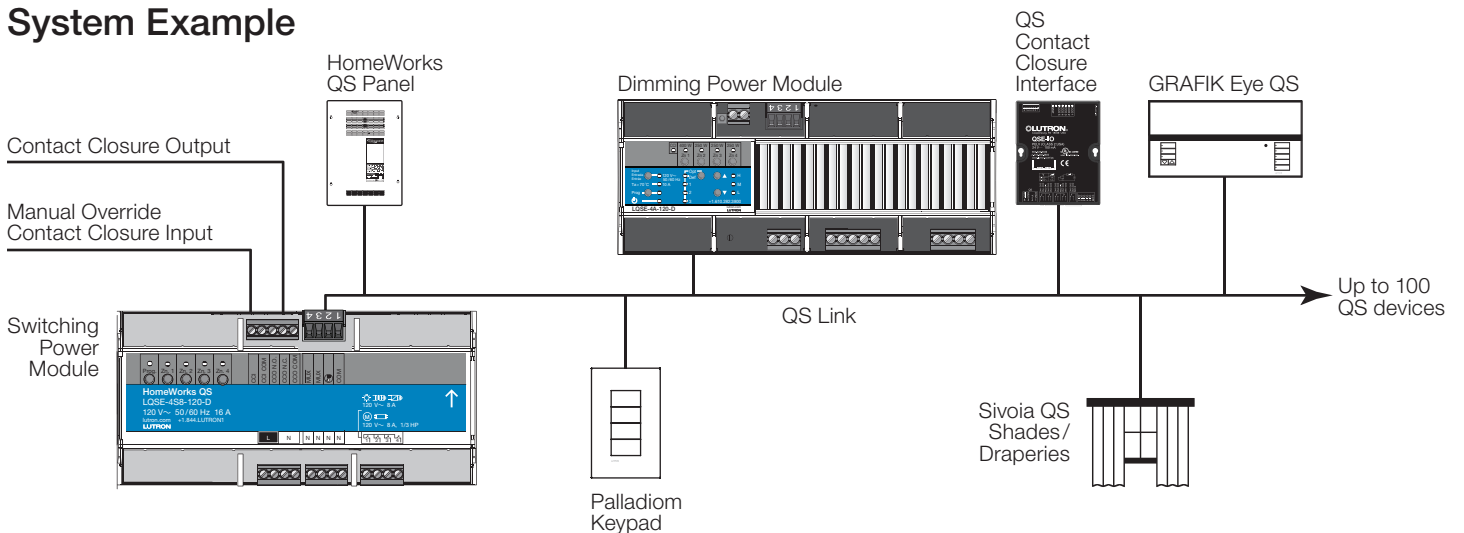

Job Name:	Model Numbers:
Job Number:	

## Specifications

### Regulatory Approvals

- Complies with cULus
- NOM Certified
- Lutron Quality Systems registered to ISO 9001.2015

### Power

- 120 V $\sim$  50/60 Hz
- Single input feed
- 16 A maximum input current
- Lightning strike protection meets ANSI/IEEE standard C62.41. Can withstand voltage surges up to 6000 V $\sim$  and current surges up to 3000 A.
- For ungrounded delta feed applications, contact Lutron.

### Environment

- For thermal specifications, see **Mounting** section
- Relative humidity: less than 90% non-condensing
- For indoor use only

### Terminals

- Mains wiring: 18 AWG to 12 AWG (1.0 mm<sup>2</sup> to 2.5 mm<sup>2</sup>) (single wire, solid or stranded)
- CCI/CCO wiring: 20 AWG to 12 AWG (0.5 mm<sup>2</sup> to 2.5 mm<sup>2</sup>) (single wire, solid or stranded)  
22 AWG to 16 AWG (0.5 mm<sup>2</sup> to 1.5 mm<sup>2</sup>) (two wires, solid or stranded)
- Zone wiring: 18 AWG to 12 AWG (1.0 mm<sup>2</sup> to 2.5 mm<sup>2</sup>) (single wire, solid or stranded)
- QS Link: 20 AWG to 12 AWG (0.5 mm<sup>2</sup> to 2.5 mm<sup>2</sup>) (single wire, solid or stranded)  
22 AWG to 18 AWG (0.5 mm<sup>2</sup> to 1.0 mm<sup>2</sup>) (two wires, solid or stranded)

### Manual Mode Operation

- Zone button on the unit can be used to turn loads on and off.

### Manual Override Contact Closure Input (CCI)

- When the CCI is open, the Switching Power Module will enter Manual Override Mode, which will turn on all loads and disable control of all local zones and QS devices. Default operation can be modified through HomeWorks QS programming software.
- When the CCI is closed or jumpered (factory default), the Switching Power Module zones will return to the settings they were at prior to entering Manual Override Mode.

### Contact Closure Output (CCO)

- Accepts voltages of 0–24 V $\sim$ /0–24 V $\equiv$ ; see chart below for load switching capacities:

Switching Voltage	Resistive Load $I_R$
0–24 V $\equiv$	1.0 A
0–24 V $\sim$	0.5 A

- Provides both normally open (N.O.) and normally closed (N.C.) dry contacts.
- Maintained or momentary output type.
- Output relay is non-latching (if relay is closed and power is lost, relay will open).
- The CCO is not rated to control unclamped, inductive loads. Inductive loads include, but are not limited to, relays, solenoids, and motors. To control these types of equipment, a flyback diode (not included) must be used (DC voltages only). See diagram below.

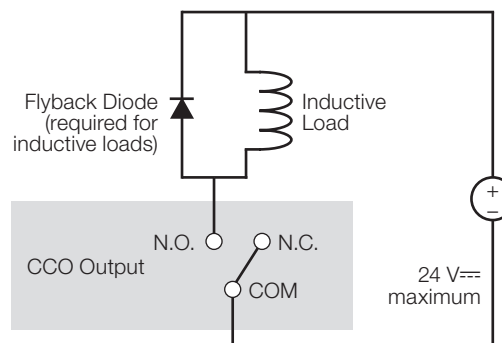

Job Name:

Model Numbers:

Job Number:

## Specifications - (continued)

### Programming and Compatibility Requirements

- Setup and programming of the Switching Power Module is done through the HomeWorks QS programming software.
- HomeWorks QS software version 12.0 or higher required.

### HomeWorks QS Wallstations

- HomeWorks QS wallstations can be configured to control Switching Power Modules with the HomeWorks QS programming software.
- Wallstation LED indicators display the status of programmed lights.

### QS Link Limits

- A QS link in a HomeWorks QS system can have up to 512 zones (outputs) and 100 devices (required HomeWorks QS processor counts as one device on the QS link).
- Each Switching Power Module counts as one device toward the 100 device limit, and 4 zones toward the 512 zone limit.

### Output Zone Ratings

- Each zone is rated at 8 A for switching. Rated for resistive, inductive, or capacitive lighting loads as defined by NEMA 410.
- Air gap off per output.
- No minimum load per output.
- This module is designed to control loads with ratings as noted in the table below.
- Outputs cannot be used to control general purpose receptacles.

Load Type	Relay Ratings
	120 V~
Tungsten	8 A/zone, 16 A max/module
AC General Use	8 A/zone, 16 A max/module
Electric Discharge Lamp	8 A/zone, 16 A max/module
Electronic Ballast (NEMA 410)	8 A/zone, 16 A max/module
Resistive	8 A/zone, 16 A max/module
Inductive	8 A/zone, 16 A max/module
Motor	8 A (1/3 HP)/zone, 16 A max/module

- Special considerations:
  - When controlling lamps, Lutron recommends using permanently installed fixtures.
  - If controlling plug-in lamps, installation must ensure a method of preventing non-rated loads being plugged into the unit. An example is Lutron P/N CAR-15-DDTR, which is a dedicated receptacle with an alternate plug type.
  - Controlling loads outside the parameters listed in the specifications may damage the device and void the warranty.
- If attempting to control general purpose receptacles, use the appropriate third-party power pack for the rated load.
- Run a separate neutral for each load circuit. A common neutral connection is not recommended.
- Unit may be powered by Ground Fault Interrupter (GFI) or Arc Fault Circuit Interrupter (AFCI) protected circuit if required.
- For applications requiring higher wattage ratings, use PHPM-SW-DV-WH or GRX-TVI for 120 V~.

**⚠WARNING – Entrapment Hazard** – May result in serious injury or death. These controls should only be used to control equipment which is visible from every control location.

**⚠WARNING – Fire Hazard** – May result in serious injury or death. Only use these controls to operate approved load and equipment types.

**IMPORTANT NOTE:** Examples of such equipment which must not be operated by these controls include (but are not limited to) motorized gates, garage doors, industrial doors, microwave ovens, heating pads, fireplaces, space heaters, etc. It is the installer’s responsibility to ensure that the equipment being controlled is visible from every control location and that only suitable equipment is connected to these controls. Failure to do so could result in serious injury or death.

<b>Job Name:</b>	<b>Model Numbers:</b>
<b>Job Number:</b>	

### Mechanical Dimensions

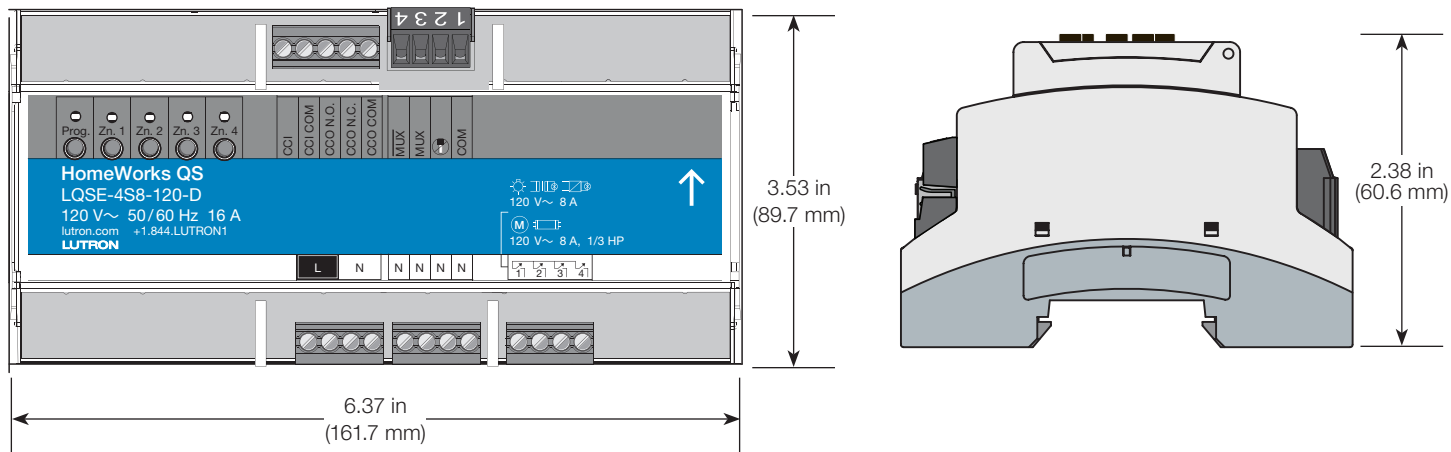

### Mounting

- Mount in a Lutron DIN Panel (see spec 3691055 at [www.lutron.com](http://www.lutron.com)) or in a NEMA Type 1 rated consumer panel or breaker panel with integrated DIN rail.
- Unit is 9 DIN modules (6.37 in [161.7 mm]) wide.
- Mount in an accessible and serviceable location.
- Unit may be mounted by pressing the unit onto the DIN rail with the clips locked. To remove the unit from the DIN rail, unlock the clips using a screwdriver.
- See Lutron P/N 048466 at [www.lutron.com](http://www.lutron.com) for more information on mounting and installation in panels with integrated DIN rail.
- Mount the Power Module where audible noise is acceptable (internal relays click).
- Unit generates heat, maximum 24 BTUs/hr.
- Mount unit such that all the conditions below are met:
  - Room ambient temperature is between 32 °F and 104 °F (0 °C and 40 °C).
  - Temperature inside mounting panel, within 0.80 in (20 mm) of unit, is between 32 °F and 104 °F (0 °C and 40 °C).
  - Calibration point maximum: 149 °F (65 °C).

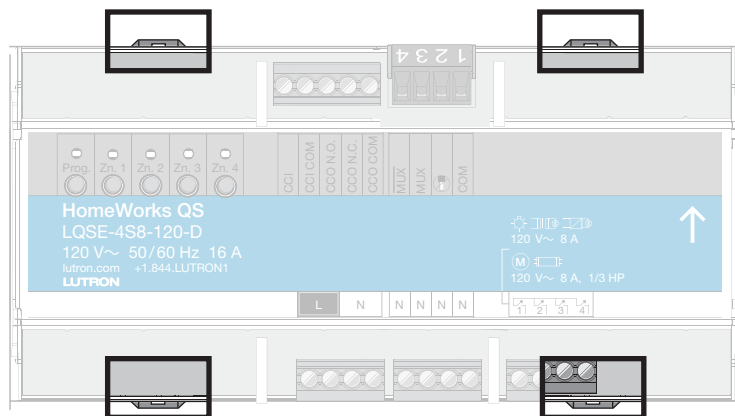

Mounting clips (4) on unit  
Locked      Unlocked

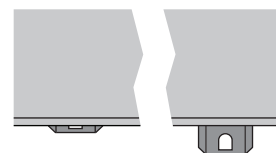

Job Name:	Model Numbers:
Job Number:	

# Wiring: Mains and Output Zones

## Wiring from Distribution to Switching Power Module

- Turn off all circuit breakers or isolators feeding the Switching Power Module at the distribution panel.
- Run line/hot and neutral wires from a 120 V~ 50/60 Hz feed to the Switching Power Module unit.
- Run a separate neutral for each load circuit. A common neutral connection is not recommended.

## Mains Wiring and NEC® Class 2 Separation

- Follow appropriate local and national codes to avoid violating required separation guidelines.

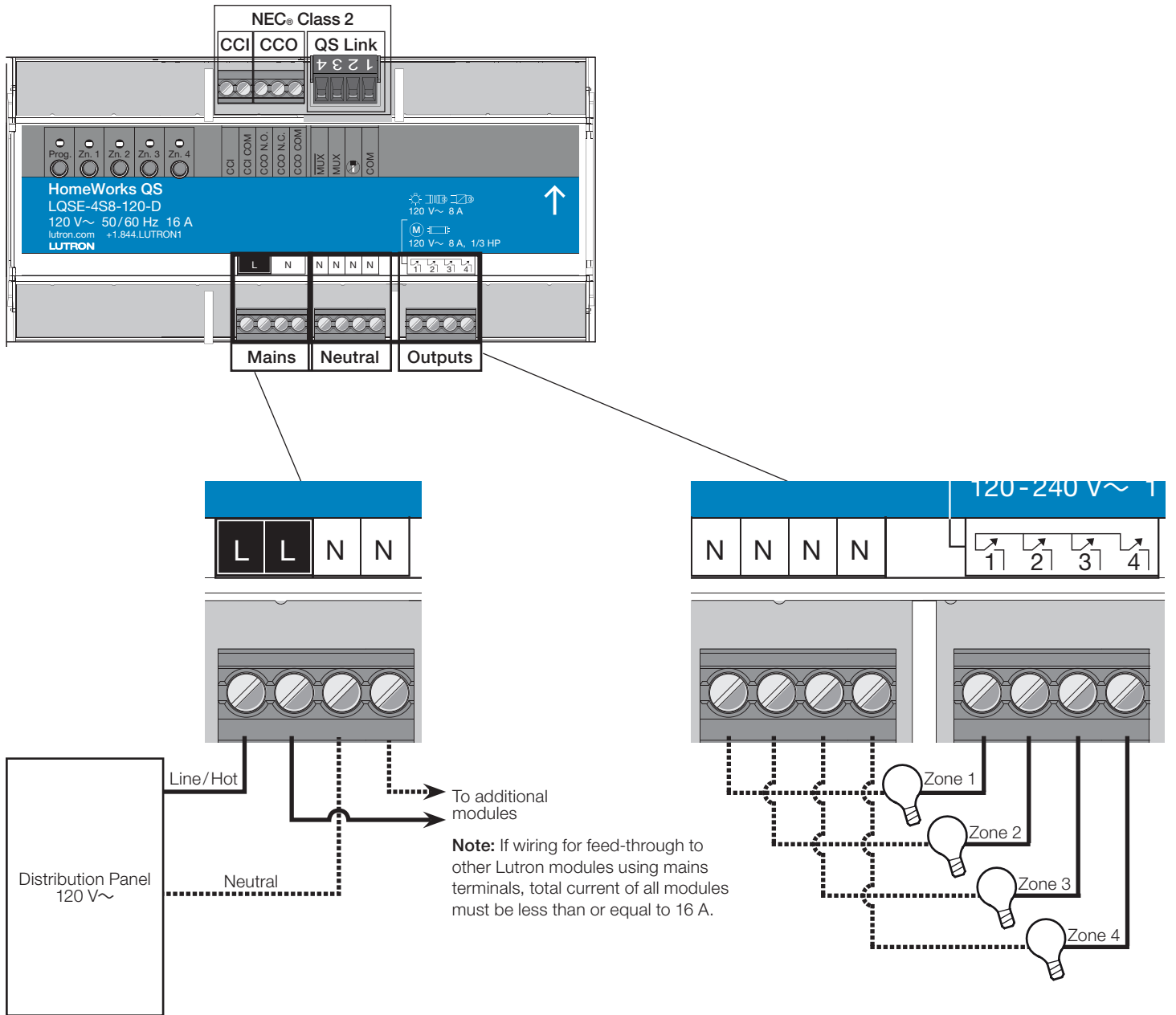

Job Name:	Model Numbers:
Job Number:	

# Wiring: Manual Override Contact Closure Input and Contact Closure Output

## NEC® Class 2 Contact Closures

- Manual Override Contact Closure Input (CCI)/ Contact Closure Output (CCO) wiring is NEC® Class 2. Follow all applicable national and local codes for proper circuit separation and protection.
- Turn off all breakers or isolators feeding the Switching Power Module at distribution panel before servicing unit.
- CCI is local control only and cannot control other units over the QS link. CCI on up to 32 units may be connected to an emergency or manual override device in parallel if event is intended to affect multiple units.
- When in Manual Override Mode:
  - All zone outputs will be switched on.
  - Controls will not affect units in Manual Override Mode.
  - Controls connected to a unit in Manual Override Mode will continue to affect units on the link that are not in Manual Override Mode.
- Manual override contact closure input is normally closed (N.C.). The Switching Power Module is shipped with a jumper pre-installed.

**Note:** The Switching Power Module will default to Manual Override Mode if the CCI is left open. If no Manual Override contact input is required, leave the wire jumper in the CCI terminals.

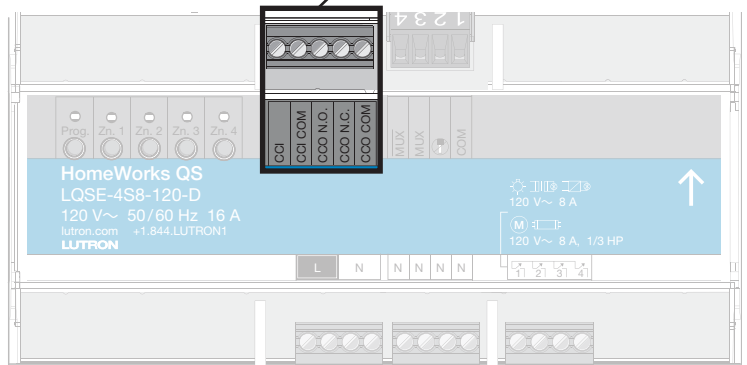
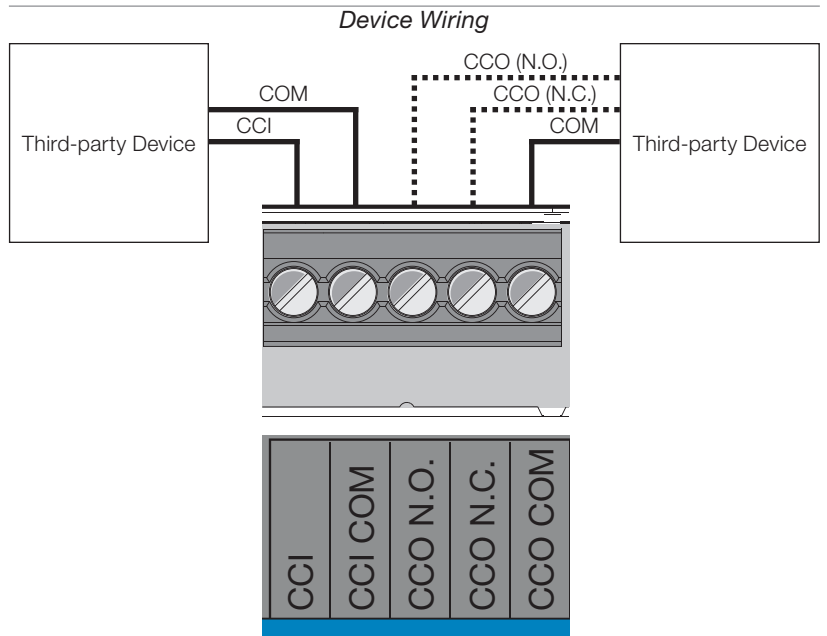
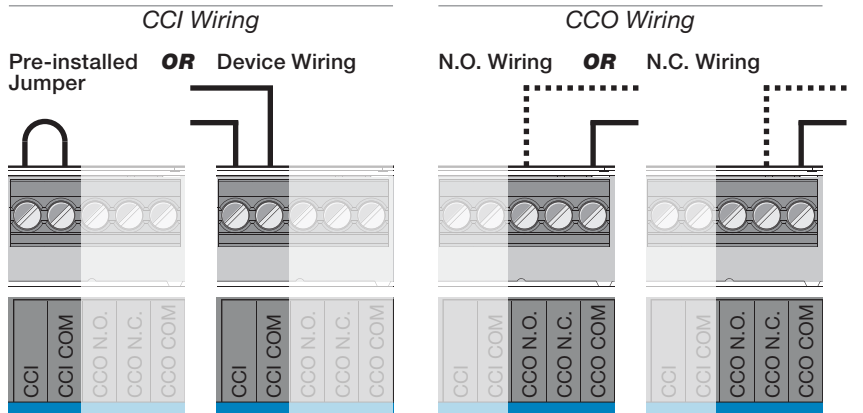

Job Name:	Model Numbers:
Job Number:	

### Wiring: QS Link

- QS link wiring is NEC® class 2. Follow all applicable local codes for proper circuit separation and protection.
- Turn off all breakers or isolators feeding the Switching Power Module at distribution panel before servicing unit.
- Wiring may be daisy chained or t-tapped.
- Total length of QS link wiring must not exceed 2000 ft (610 m).
- Wire Gauge:
  - Control (terminal 1): 18 AWG (1.0 mm<sup>2</sup>).
  - Data (terminals 3 and 4): 1 pair 22 AWG to 18 AWG, (0.5 mm<sup>2</sup> to 1.0 mm<sup>2</sup>) twisted and shielded.
  - Can use Lutron cable GRX-CBL-346S-500 (less than 500 ft [150 m]) or GRX-CBL-46L (500 ft to 2000 ft [150 m to 610 m]).
- See “HomeWorks QS Wiring Guidelines” application note on [www.myLutron.com](http://www.myLutron.com)

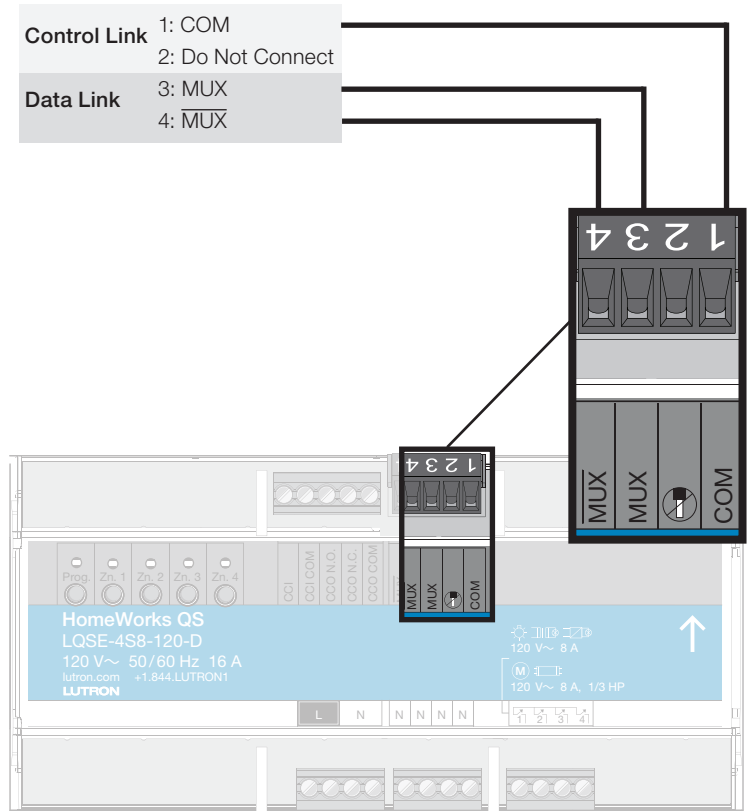

The Lutron logo, Lutron, HomeWorks, Sivoia, Palladiom, and GRAFIK Eye are trademarks or registered trademarks of Lutron Electronics Co., Inc. in the US and/or other countries. All other product names, logos, and brands are property of their respective owners.

<p><b>Job Name:</b></p> <p><b>Job Number:</b></p>	<p><b>Model Numbers:</b></p>
--	------------------------------