

HomeWorks Wireless Processor

HomeWorks wireless processors can communicate with up to 100 Clear Connect – Type X devices, 95 Clear Connect – Type A devices, and 4 Type A repeaters per processor.



Features

- Powered by an IEEE 802.3af, IEEE 802.3at or IEEE 802.3bt compliant LPS/SELV PoE or PoE+ power supply. See Lutron models Q-POE-PNL, L-POEI-BL. Other compatible devices may also be used.
- The HomeWorks wireless processor is compatible with Sunnata dimmers/switches/keypads, Maestro dimmers/switches/fan controls, Pico controls, Radio Powr Savr sensors, Triathlon and Sivoia QS wireless shades, seeTouch keypads, HomeWorks plug-in dimmers and switches, HomeWorks RF dimmer and switch modules, and Ketra wireless fixtures and lamps. Other products may also be compatible; see individual product spec sheets for details on system compatibility.
- **Note:** Refer to the installation instructions of the HomeWorks QSX processor for setup and other information. A maximum of 16 total gateways, wireless processors, and wired processors can be on one system. Ensure you are using the latest version of the Lutron Designer software.

HomeWorks Wireless Processor

Specifications

Model Number	HQP7-RF-2
PoE Power	48 V $\overline{=}$ 100 mA (IEEE 802.3af, IEEE 802.3at or IEEE 802.3bt compliant PoE supply)
Regulatory Approvals	cULus, FCC, IC, NOM, ANATEL
Communications	434 MHz RF (Clear Connect - Type A) 2.4 GHz RF (Clear Connect - Type X)
Environment	Ambient operating temperature: 32 to 104 °F (0 to 40 °C) 0% to 90% humidity, non-condensing. Indoor use only.
Heat Generated	14 BTU/hr – typical
ESD Protection	Tested to withstand electrostatic discharge without damage or memory loss, in accordance with IEC 61000-4-2.
Surge Protection	Tested to withstand surge voltages without damage or loss of operation, in accordance with IEEE C62.41-1991 Recommended Practice on Surge Voltages in Low-Voltage AC Power Circuits.
Power Failure	Should power be interrupted, the wireless processor will return to its previous state when power is restored.
Wiring	Use Cat5e minimum cable. Maximum length is 328 ft (100 m) from router to processor including the PoE injector. Each wireless processor needs to have a home run Ethernet connection back to the PoE supply.
Warranty	www.lutron.com/TechnicalDocumentLibrary/HomeWorks_Warranty.pdf

Mounting Reliability of Clear Connect wireless communication requires that the wireless processor be centrally-located and within a maximum distance of the specific wireless devices in the system. A maximum of 16 total gateways, wireless processors, and wired processors can be on one system. Wireless processors must be mounted 5 ft (1.5 m) away from wireless interference sources like microwaves, Wireless Access Points (WAPs), etc. PoE wiring must be kept internal to the building. Do not run PoE wiring outdoors or install the processor in metallic enclosures. Wireless processor cannot span multiple floors.

Distances for Wireless Devices

Clear Connect – Type A Devices (see Touch keypads, Maestro dimmers, Pico wireless controls, Sivoia QS wireless shades, etc.)

- Each device must be within 30 ft (9 m) of a repeater or wireless processor.
- Repeaters can be spanned up to 60 ft (18 m) apart from other repeaters to create the network.

Clear Connect – Type X Devices

- All devices associated with the wireless processor must be within a 75 ft (23 m) radius of the processor.
- There must be a minimum of two devices within 25 ft (7.6 m) of the wireless processor.
- Each Clear Connect – Type X device should have two or more non-battery powered Type X devices within 25 ft (7.6 m) of another compatible Clear Connect – Type X device. Using more than two devices is ideal for creating an ultra high-performance mesh network.

For myLutron users, please see Application Note #745 (P/N 048745) for additional information on Clear Connect – Type X Best Practices on www.lutron.com

Replacement Parts

Model Number	Description
L-CMNT-WH	Recess-mount adapter
L-JMNT-WH	Junction box mount adapter
L-SMNT-WH*	Shelf-mount adapter
L-POEI-BL	PoE injector with U.S. clip, 6 ft (1.8 m) down-angle Ethernet cable and 3 ft (0.9 m) Ethernet cable

* Needs down-angle Ethernet cable similar to the one included in the L-POEI-BL.

HomeWorks Wireless Processor

HomeWorks QSX System Security Statement

Lutron takes cybersecurity very seriously. We actively monitor the threat landscape and take a proactive approach to security and privacy, continuously working to update and enhance our systems and processes.

At Lutron, we call our approach to cybersecurity **“Secure Lifecycle”**, and we would like to present the following steps we take to protect your security and privacy:

- **Security by Design.** When building a new system, Lutron utilizes a dedicated security team to ensure best practices are implemented. Security is built in. It is not an afterthought or an add-on.
- **Third-Party Validation.** Security is complicated. Lutron has a dedicated team of internal experts, but we also leverage external experts to double-check our work and to make security recommendations.
- **Continuous Monitoring and Improvements.** Security is a constantly moving target. Lutron uses a dedicated security team to continuously monitor for potential threats and, when needed, send out security patches to update installed systems.
- **Ongoing Support.** Lutron has the resources you need to answer questions about security when they arise.

We incorporate a variety of security features into our product designs. These features include recommendations from the National Institute of Standards and Technology (NIST) among others, and they are aimed at meeting our secure lifecycle protections. While we do not publish a comprehensive list of our security features, the following list is a small example of some of the techniques employed in our system designs for HomeWorks QSX processors, Clear Connect – Type X Gateway, and HomeWorks wireless processor devices and associated services (such as mobile applications and cloud resources):

1. Secure and authenticated remote access with unique keys for every HomeWorks QSX system.
2. A secure hardware element (“chip”) on all HomeWorks QSX processors, Clear Connect – Type X Gateway, and HomeWorks wireless processor devices to guard the keys used for secure communication and authentication.
3. Enforcing industry-standard encrypted communication and techniques for our integration protocols to the highest extent possible. Any integrated third-party components or systems should be evaluated independently.
4. Secure commissioning – all communication between the system programming software tool/app and the processors is encrypted and authenticated. Programming a system requires permission to access that system.
5. Security updates are pushed out automatically to the lighting system for urgent security patches. Lutron is committed to one year of security support from system start-up date.
6. Use of industry-standard techniques for cloud-based integrations, such as OAuth2.0
7. Signed processor firmware to ensure a firmware update is authentically from Lutron.

If you have additional questions or would like to make a vulnerability disclosure to Lutron, please contact Lutron’s 24/7 Technical Support Line at 1.844.LUTRON1 or email us at support@lutron.com

HomeWorks Wireless Processor

Dimensions

Wireless Processor

Front View

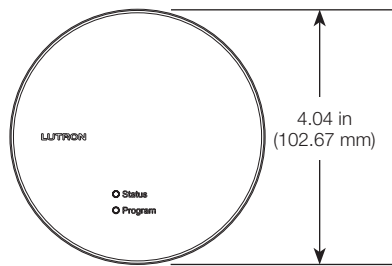

Bottom View

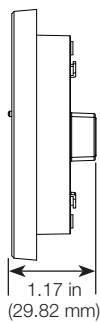

Back View

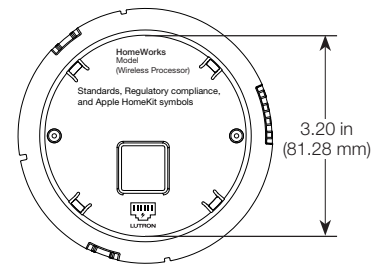

Shelf-mount Adapter *(sold separately)*

Front View

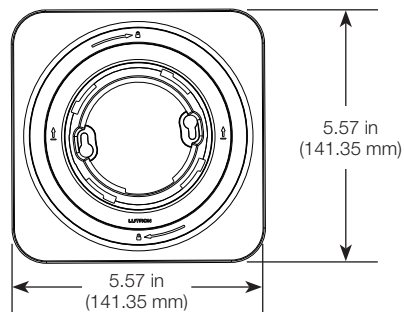

Side View

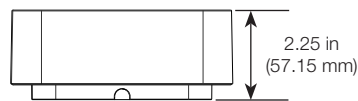

Detail View

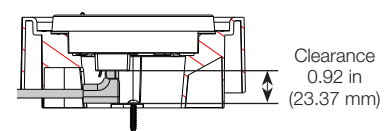

HomeWorks Wireless Processor

Dimensions *(continued)*

Recess-mount Adapter *(included)*

Front View

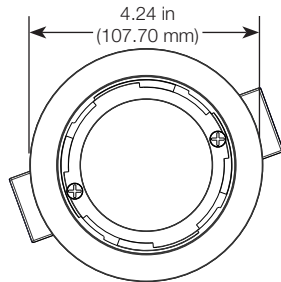

Side View

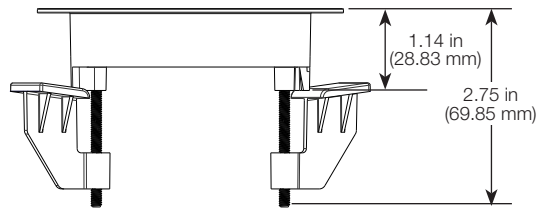

Junction Box Mount Adapter *(included)*

Front View

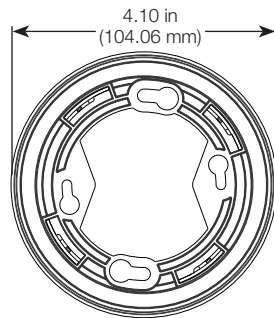

Side View



HomeWorks Wireless Processor

Mounting

Recess-mount Adapter (included)
P/N: L-CMNT-WH

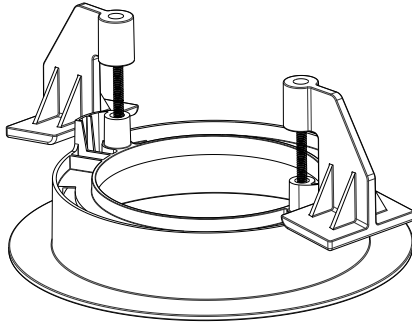

Junction Box Mount Adapter (included)
P/N: L-JMNT-WH

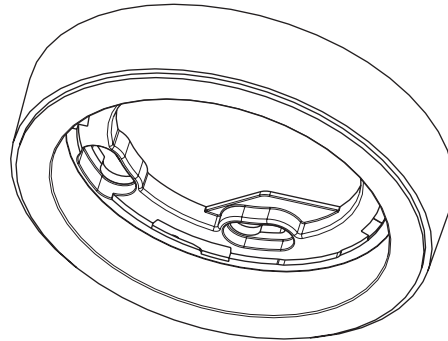

Shelf-mount Adapter (sold separately)
P/N: L-SMNT-WH

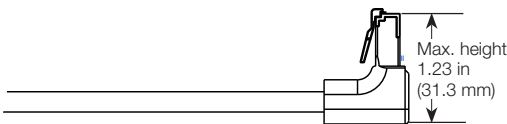
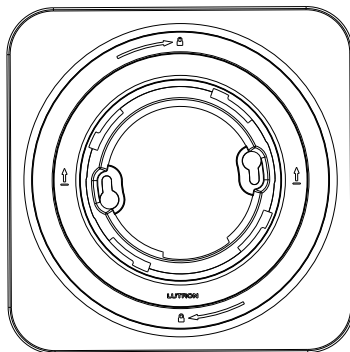

Note: The low-profile of the shelf mount adapter requires a down-angle Ethernet cable with a maximum height of 1.23 in (31.3 mm). See down-angle Ethernet cable included in L-POEI-BL.

For detailed installation instructions on all mounting methods, please see the HomeWorks wireless processor install guide at www.lutron.com.

Lutron, Clear Connect, HomeWorks, Maestro, Pico, Radio Powr Savr, seeTouch, Sivoia, Sunnata, and Triathlon are trademarks or registered trademarks of Lutron Electronics Co., Inc. in the US and/or other countries.
 Ketra is a trademark or registered trademark of Lutron Ketra LLC, in the US and/or other countries.
 All other product names, logos, and brands are property of their respective owners.