

QS Sensor Module

The QS Sensor Module (QSM) is a ceiling-mounted device that integrates Lutron® wireless and wired sensors through the wired QS Link on a HomeWorks® QS processor.

- The QSM uses Clear Connect® RF Technology for communication with up to 10 Radio Powr Savr™ occupancy/vacancy sensors and 10 Pico® wireless controls.
- The QSM connects up to four Lutron® wired occupancy sensors.
- No line voltage connections are required because the QSM is powered by the QS Link.



Model Numbers

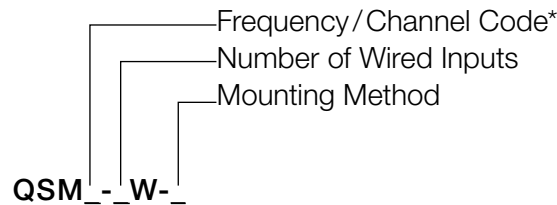

Frequency/Channel Code*

- 2—431.5 – 436.6 MHz U.S.A., Canada and Mexico
- 3—868.1 – 869.8 MHz European Union and United Arab Emirates
- 4—868.1 – 868.5 MHz Singapore and China
- 5—865.5 – 866.5 MHz India
- 7—433.0 – 434.7 MHz Hong Kong
- X—No RF

Number of Wired Inputs

- 4—4
- X—None

Mounting Method

- C—Ceiling Mount
- J—Junction Box Ceiling Mount

* Contact Lutron for frequency/channel code compatibility with your geographic region if it is not indicated above.

QS Sensor Module

Specifications

Model Numbers	QSM2-4W-C, QSM2-XW-C, QSM2-4W-J, QSM2-XW-J QSM3-4W-C, QSM3-XW-C QSM4-4W-C, QSM4-XW-C QSM5-XW-C QSM7-4W-C, QSM7-XW-C QSMX-4W-C
Power	24 V $\overline{=}$ 400 mA max (wired input), 100 mA max (no wired input)
Typical Power Consumption	1.5 W; 3 Power Draw Units* (PDUs), plus 2 PDUs for each wired sensor * For more information about PDUs, please see the HomeWorks [®] QS Wiring and Power Guidelines document on the HomeWorks [®] QS Resource Website.
Regulatory Approvals	cUL US, FCC, IC, SCT, CE, TRA, WPC
Environment	Ambient operating temperature: 32 to 104 °F (0 to 40 °C) 0% to 90% humidity, non-condensing. Indoor use only
Communications	The QSM communicates with the system through the Wired QS Link. When communicating via RF, all wireless sensors and Pico [®] wireless controls must be within 30 ft (9 m) through typical construction materials.
Link Capacities	The QSM counts as 1 device toward the link maximum of 100 devices. Wired sensors increase the PDU (Power Draw Units) of the QSM.
ESD Protection	Tested to withstand electrostatic discharge without damage or memory loss, in accordance with IEC 61000-4-2.
Surge Protection	Tested to withstand surge voltages without damage or loss of operation, in accordance with IEEE C62.41-1991 Recommended Practice on Surge Voltages in Low-Voltage AC Power Circuits.
Power Failure	Power failure memory: Should power be interrupted, the QSM will return to its previous state when power is restored.
Mounting	To ensure optimal wireless range, QSM units should be mounted in the middle of non-metal ceiling tile or drywall, visible from inside the space. Installation near metal other than a junction box may reduce RF range.
Wiring	QS Link: 22 to 14 AWG (0.5 to 2.5 mm ²) IEC PELV/NEC [®] Class 2 wiring Maximum QS Link length 2000 ft (610 m) Input: 22 to 14 AWG (0.5 to 2.5 mm ²) IEC PELV/NEC [®] Class 2 wiring Use Lutron [®] cable GRX-CBL-346S (standard) or GRX-PCBL-346S (plenum)
Warranty	www.lutron.com/TechnicalDocumentLibrary/HomeWorks_Warranty.pdf www.lutron.com/TechnicalDocumentLibrary/HomeWorks_Intl_Warranty.pdf

QS Sensor Module

Dimensions

Front View

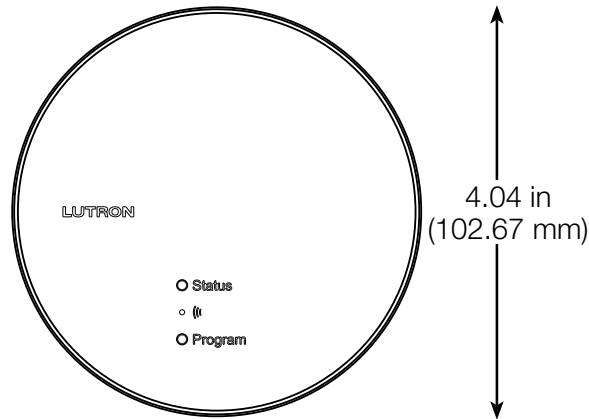

4.04 in
(102.67 mm)

Side View

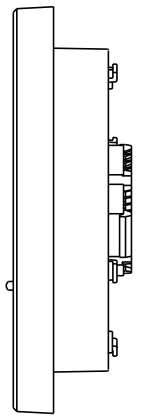

1.17 in
(29.82 mm)

Back View

(QSM2-4W-C shown)

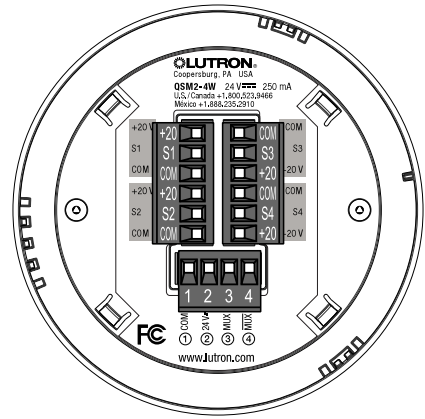

Mounting

-C Models

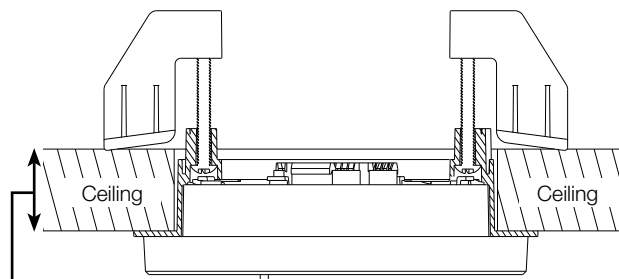

Ceiling thickness range for -C models
Min: 0.30 in (7.62 mm)
to
Max: 1.20 in (30.48 mm)

-J Models

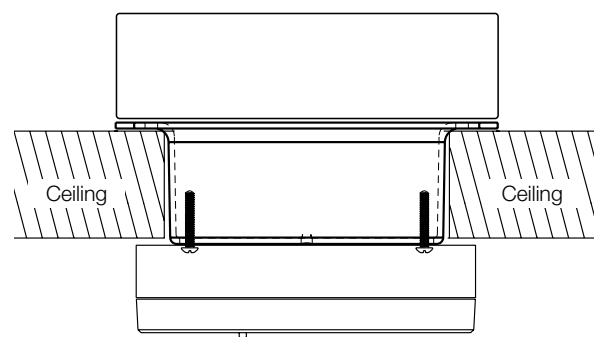

Use appropriate Mud Ring for ceiling tile thickness

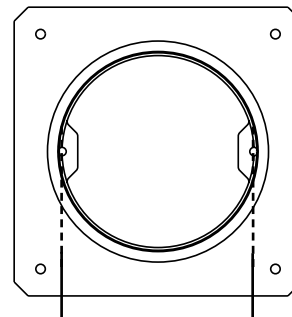

Use Mud Ring with hole spacing shown below.
(Mud Ring not included with any QSM models)

2.75 in (70 mm)

QS Sensor Module

Wiring: QS Link and Wired Inputs

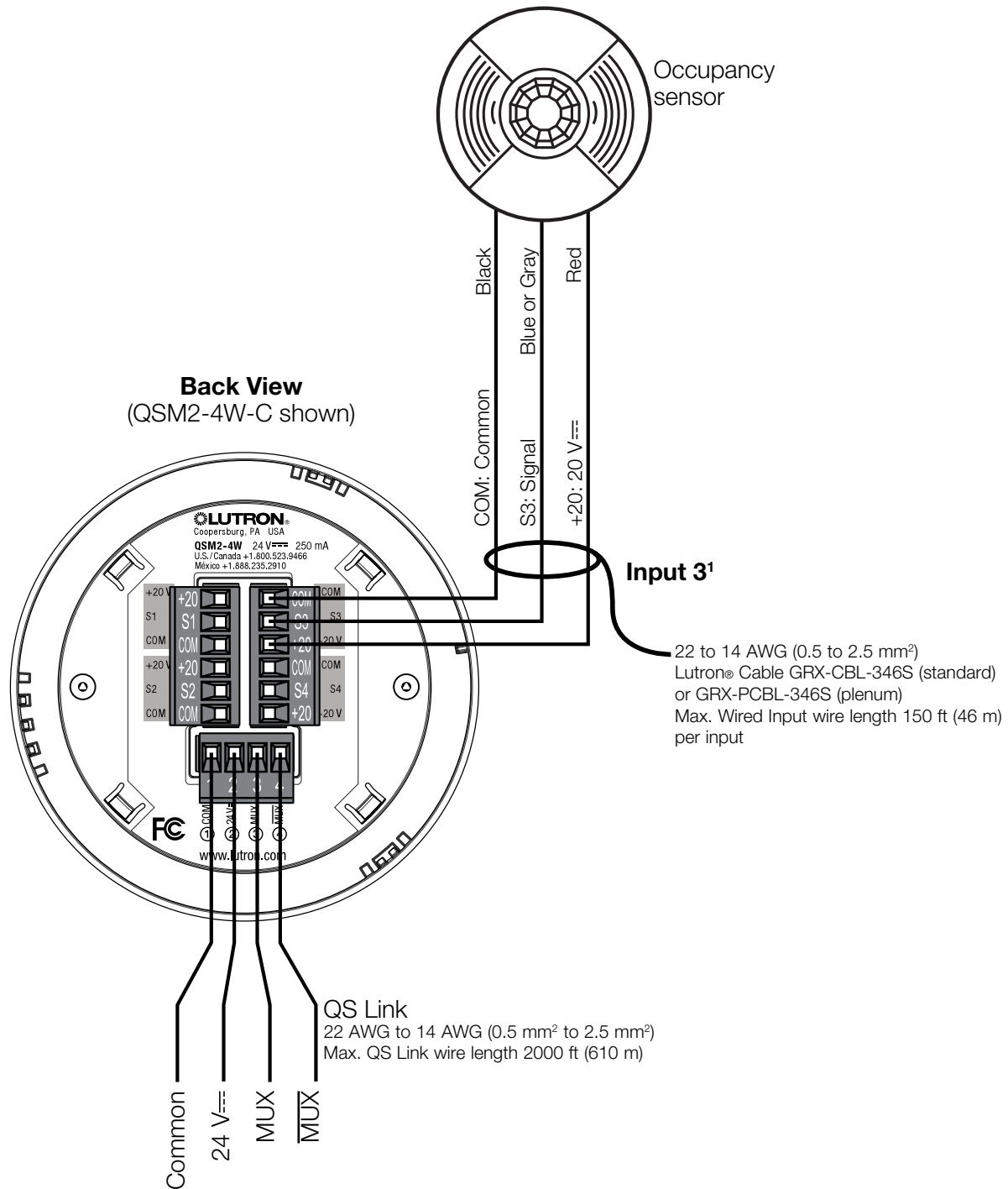

¹ Only on QSM models with wired inputs.

QS Sensor Module

System Wiring Diagram

