

## QS Wired Palladiom Keypad

The QS wired Palladiom Keypad allows the user to control Lutron load-control devices via a QS link.

### Features

- Large buttons are easy to use
- Buttons with white, backlit engraving make it easy to find and operate the keypad in low-light conditions
- Button engraving is easy to read
- Available in a variety of colors and finishes
- Keypad available in a variety of button marking options
- Wires to the QS link
- Works within Quantum, myRoom Plus, and myRoom Prime systems
- Status of active button press or scene is indicated through intensity of backlighting
- Dynamic Backlighting Management (DBM) automatically adjusts backlighting intensity based on ambient lighting conditions
- Backlighting can also be programmed in Quantum and myRoom systems to adjust backlighting intensity

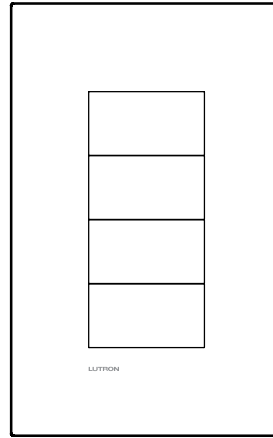

1-Gang U.S. Style

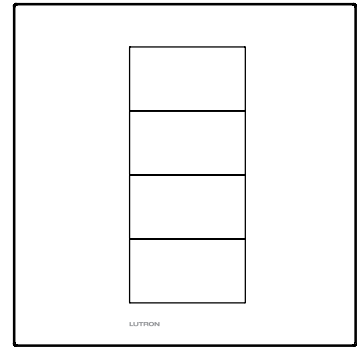









1-Column Square Style

### Colors and Finishes

#### Architectural Matte Finishes

-  Almond  
**AL**
-  Beige  
**BE**
-  Black  
**BL**
-  Brown  
**BR**
-  Gray  
**GR**
-  Ivory  
**IV**
-  Light Almond  
**LA**
-  Sienna  
**SI**
-  Taupe  
**TP**
-  White  
**WH**

#### Architectural Metal Finishes

-  Antique Brass\*  
**QB**
-  Bright Brass  
**BB**
-  Bright Chrome  
**BC**
-  Bright Nickel  
**BN**
-  Polished Graphite  
**PG**
-  Satin Brass  
**SB**
-  Satin Chrome  
**SC**
-  Satin Nickel  
**SN**

#### Signature Metal Finishes

-  Graphite  
**GP**

#### Glass Finish

-  Clear Black Glass  
**CBL**
-  Clear White Glass  
**CWH**

- Due to printing limitations, colors and finishes shown cannot be guaranteed to perfectly match actual product colors.
- PD-CK-1 finish chip sample set is available to represent these colors and finishes. Chips should not be used for exact matching of the color or finish.\*\*

\* Antique Brass is a handcrafted finish that is created using a manual relief process. This artisanal process can result in variations in luster, hue and appearance.  
\*\* Contact Lutron prior to using any samples for matching of non-Lutron product.

|                    |                       |
|--------------------|-----------------------|
| <b>Job Name:</b>   | <b>Model Numbers:</b> |
| <b>Job Number:</b> |                       |

## Specifications

### Regulatory Approvals

- Lutron Quality Systems registered to ISO 9001:2015
- Complies with UL 508
- Complies with IEC 60669-2-1
- Complies with CSA C22.2 No. 14-13
- Complies with UL 2269 (EBB-1-3COL only)
- Complies with IEC 60670-1 (EBB-1-3COL only)
- Complies with CSA C22.2 No. 18.2 (2006) (EBB-1-3COL only)

### Power Input

- SELV/PELV/NEC® Class 2
- Operating voltage: 24–36 V $\overline{=}$  30 mA

### System Communication and Capacity

- SELV/PELV/NEC® Class 2 wiring connects Keypads to other devices on the QS Link
- A Quantum system can have up to 100 QS devices on the QS link
- A myRoom Plus or myRoom Prime system can have up to 50 QS devices on the QS link
- Each base unit counts as 1 device on the QS link
- Each button column of a QS wired Palladiom Keypad consumes 1 power draw unit (PDU) on the QS link. For complete information, see “Power Draw Units on the QS Link” (Lutron P/N 369405) at [www.lutron.com](http://www.lutron.com)

### Terminals

- Each terminal accepts up to two 18 AWG (1.0 mm<sup>2</sup>) wires.

### Environment

- Ambient operating temperature: 32 °F to 104 °F (0 °C to 40 °C)
- Maximum 90% non-condensing relative humidity
- Indoor use only

### Key Design Features

- Field-changeable button and faceplate assemblies allow for customization. See **How to Build a Model Number (Button Kits)** for more information
- Meets IEC 801-2. Tested to withstand 15 kV electrostatic discharge without damage or memory loss
- Faceplate snaps on with no visible means of attachment
- Use Faceplate or Button Kits to change color or engraving
- Engraving font: 11- or 14-pt Helvetica; special characters available (e.g., ç, ñ); Chinese and Arabic languages NOT available
- IP20 Rating
- Control operation complies with ADA standards for an accessible design

### Compatibility

- QS wired Palladiom Keypads are compatible with:
  - Quantum systems
  - myRoom Plus systems
  - myRoom Prime systems

### Mounting

- Typical U.S. style wallbox dimensions: 3.7 in (95 mm) H × 1.8 in (46 mm) W × 2.8 in (70 mm) D
- Typical Square style wallbox dimensions: 75 mm H × 75 mm W × ≥25 mm D
- Typical Round style wallbox dimensions:  $\phi$  68 mm × ≥25 mm D
- See **Mounting** for more details

|  |                       |
|--|-----------------------|
| <b>Job Name:</b><br><br><b>Job Number:</b> | <b>Model Numbers:</b> |
|--|-----------------------|

# Dimensions

## U.S. Style - Plastic, Glass, or Metal Finish

Measurements shown as: in (mm)

### 1-Gang

Front View

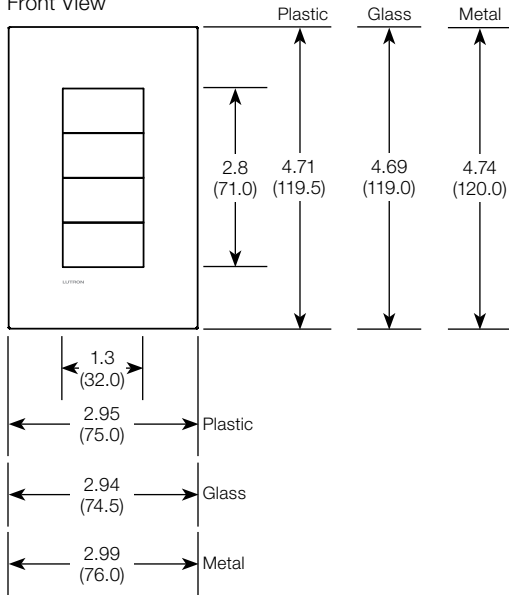

Side View

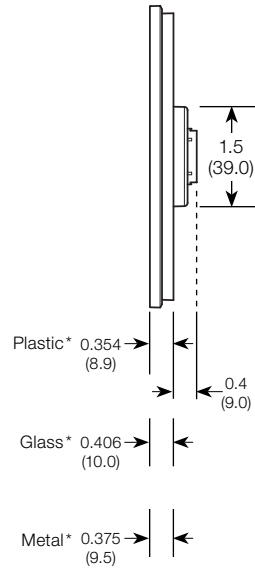

### 2-Gang

Front View

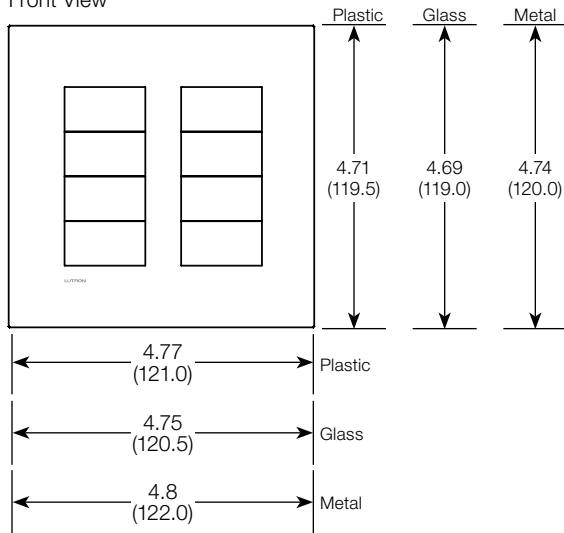

Side View

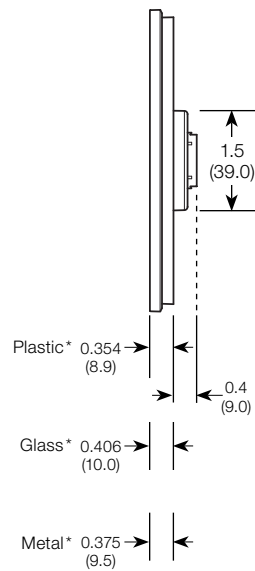

\* Wallbox installation will affect this dimension.

(continued on next page...)

|                    |                       |
|--------------------|-----------------------|
| <b>Job Name:</b>   | <b>Model Numbers:</b> |
| <b>Job Number:</b> |                       |

### Dimensions *(continued)*

#### U.S. Style - Plastic, Glass, or Metal Finish *(continued)*

Measurements shown as: in (mm)

##### 3-Gang

Front View

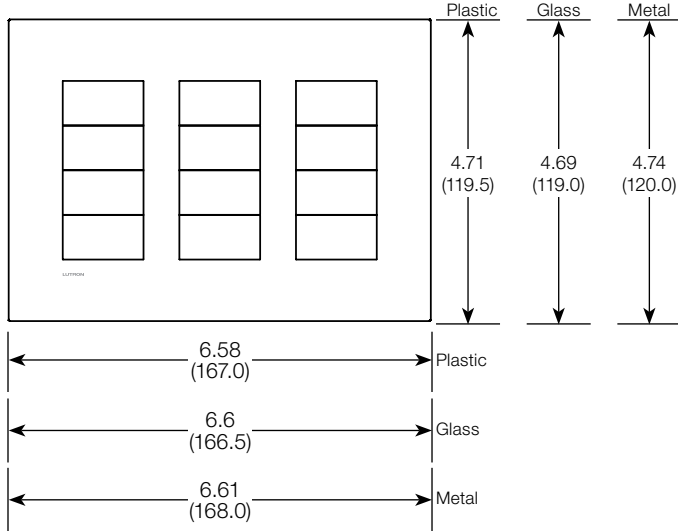

Side View

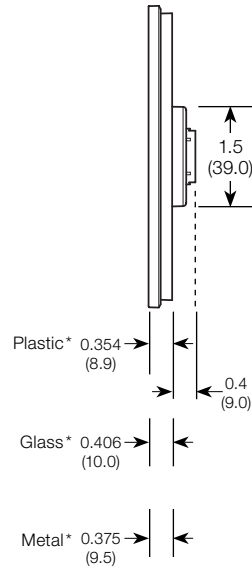

##### 4-Gang

Front View

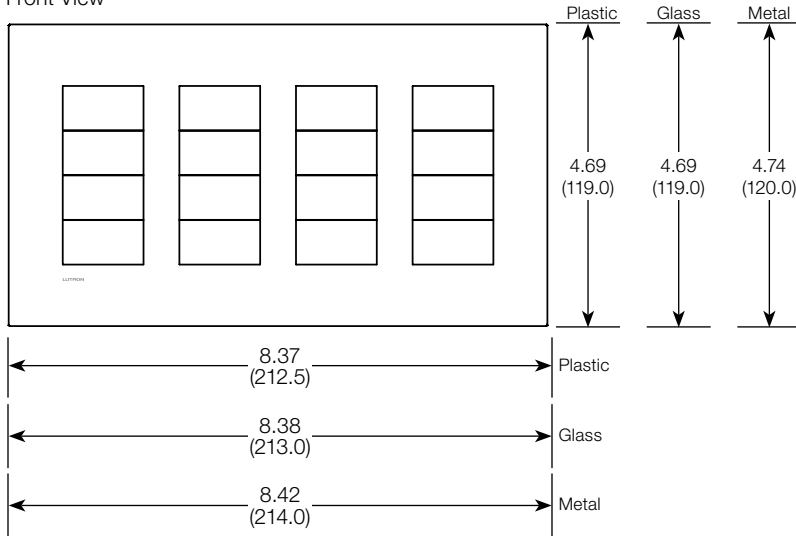

Side View

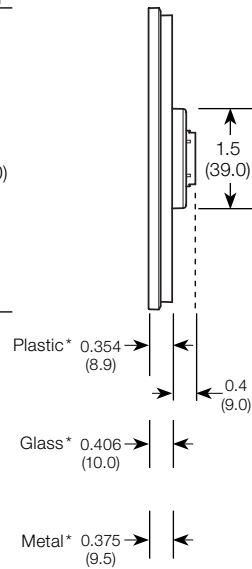

\* Wallbox installation will affect this dimension.

|                    |                       |
|--------------------|-----------------------|
| <b>Job Name:</b>   | <b>Model Numbers:</b> |
| <b>Job Number:</b> |                       |

## Dimensions *(continued)*

### Square Style - Plastic, Glass, or Metal Finish

Measurements shown as: mm (in)

#### 1-Column

Front View

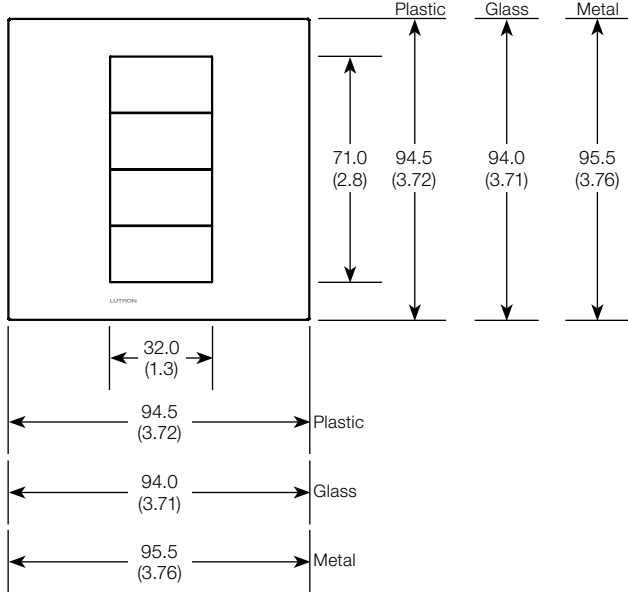

Side View

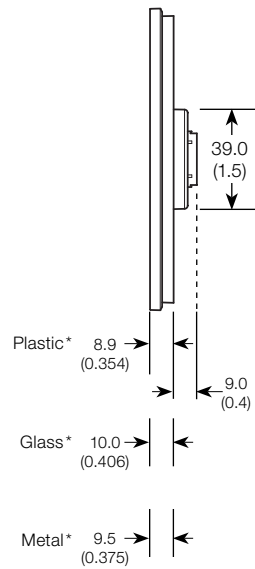

#### 2-Column

Front View

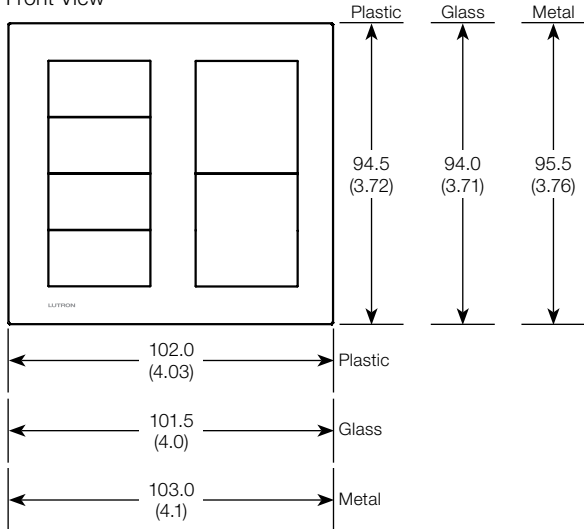

Side View

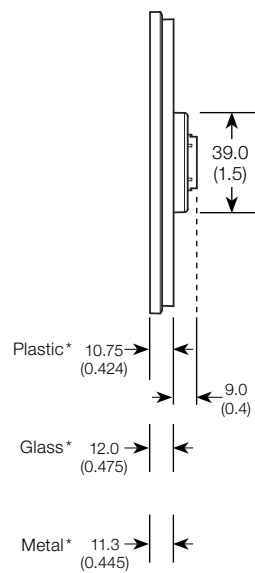

\* Wallbox installation will affect this dimension.

|                    |                       |
|--------------------|-----------------------|
| <b>Job Name:</b>   | <b>Model Numbers:</b> |
| <b>Job Number:</b> |                       |

### Dimensions *(continued)*

#### Square Style - Plastic, Glass, or Metal Finish *(continued)*

Measurements shown as: mm (in)

##### 3-Column

Front View

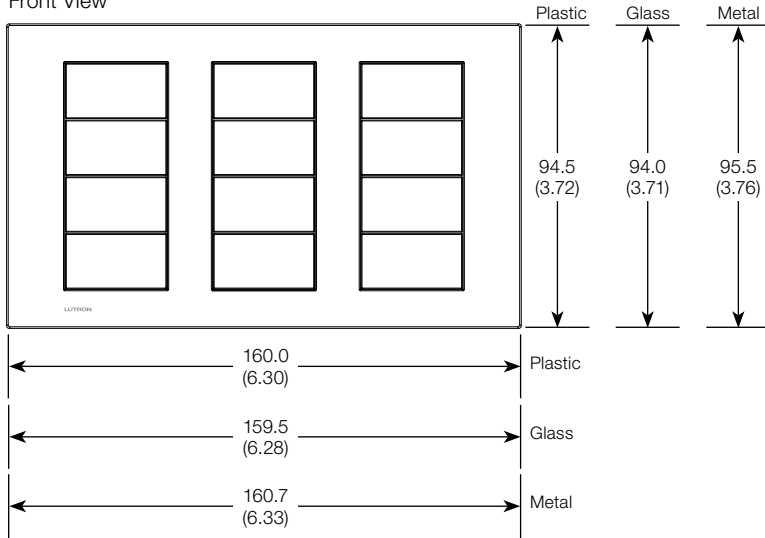

Side View

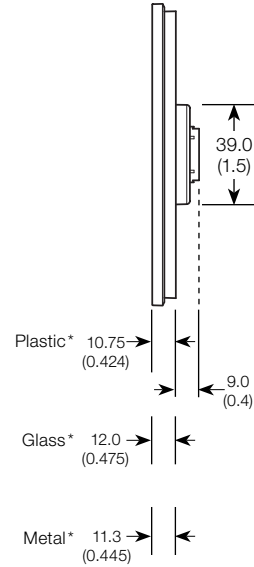

##### 4-Column

Front View

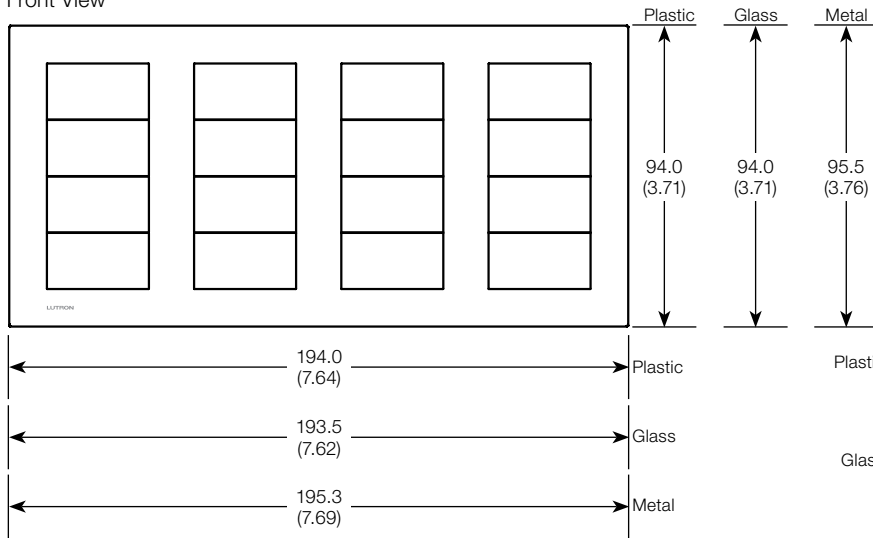

Side View

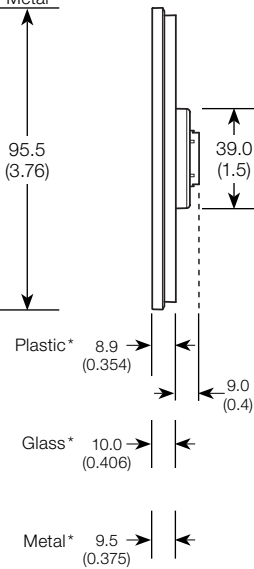

\* Wallbox installation will affect this dimension

|                    |                       |
|--------------------|-----------------------|
| <b>Job Name:</b>   | <b>Model Numbers:</b> |
| <b>Job Number:</b> |                       |

## How to Build a Model Number

### Keypads

**QWP** – **U** – **2**

#### System Type

**QWP:** Quantum

**MWP:** myRoom  
(Plus or Prime)

#### Faceplate Options

**B:** Base Unit without Faceplate\*

**U:** U.S. Style

**S:** Square Style

\* Base units are not interchangeable between plastic, metal, and glass.

#### Button Configurations

*1-Gang/Column, U.S. or Square Style*

**2:** 2-Button

**3:** 3-Button

**4:** 4-Button

**R:** 3-Button with Raise/Lower

*2-Column Square Style\**

*Left Column      Right Column*

**22:** 2-Button      2-Button

**24:** 2-Button      4-Button

**2R:** 2-Button      3-Button with  
Raise/Lower

**R2:** 3-Button with  
Raise/Lower      2-Button

**RR:** 3-Button with  
Raise/Lower      3-Button with  
Raise/Lower

**42:** 4-Button      2-Button

**44:** 4-Button      4-Button

**4R:** 4-Button      3-Button with  
Raise/Lower

**R4:** 3-Button with  
Raise/Lower      4-Button

\* 2-column keypads require predefined custom engraving (-E)

**W** – **WH** – **E**

#### Backlighting

**W:** White

#### Colors and Finishes

*Architectural Matte Finishes*

**AL:** Almond

**BE:** Beige

**BL:** Black

**BR:** Brown

**GR:** Gray

**IV:** Ivory

**LA:** Light Almond

**SI:** Sienna

**TP:** Taupe

**WH:** White

*Architectural Metal Finishes*

**BB:** Bright Brass

**BC:** Bright Chrome

**BN:** Bright Nickel

**PG:** Polished Graphite

**QB:** Antique Brass

**SB:** Satin Brass

**SC:** Satin Chrome

**SN:** Satin Nickel

*Signature Metal Finishes*

**GP:** Graphite

*Glass Finish*

**CBL:** Clear Black  
Glass

**CWH:** Clear White  
Glass

#### Engraving

See Engraving Options for more details

**E:** Predefined custom engraving\*\*

\* Customer must provide engraving details at time of order.

\*\* Required for any 2-column keypad.

|                    |                       |
|--------------------|-----------------------|
| <b>Job Name:</b>   | <b>Model Numbers:</b> |
| <b>Job Number:</b> |                       |

## How to Build a Model Number *(continued)*

### Button Kits

Use Button Kits to change color, button configuration, and engraving. Each Button Kit includes a button assembly.

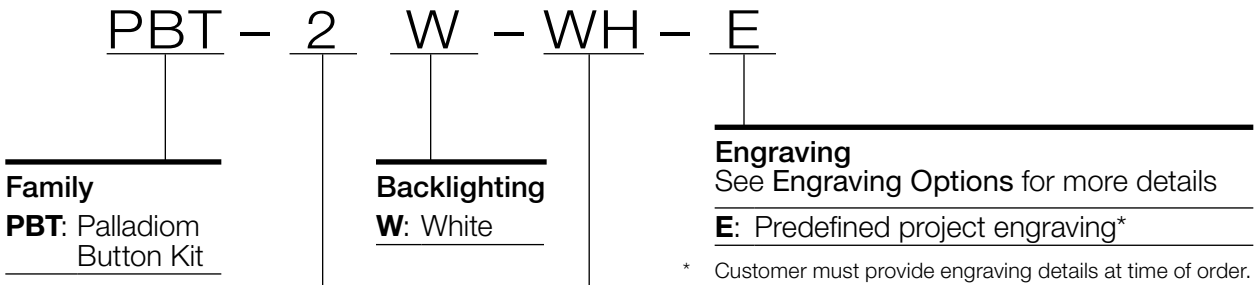

### Button Configurations

*1-Gang/Column,  
U.S. or Square Style*

**2:** 2-Button



**3:** 3-Button



**4:** 4-Button



**R:** 3-Button with Raise/Lower

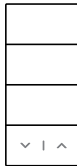

### Colors and Finishes

Colors and Finishes for buttons and faceplates must always match (e.g., matte plastic buttons with matte plastic faceplate, metal buttons with metal faceplate).

#### *Architectural Matte Finishes*

**AL:** Almond

**BE:** Beige

**BL:** Black

**BR:** Brown

**GR:** Gray

**IV:** Ivory

**LA:** Light Almond

**SI:** Sienna

**TP:** Taupe

**WH:** White

#### *Architectural Metal Finishes*

**BB:** Bright Brass

**BC:** Bright Chrome

**BN:** Bright Nickel

**PG:** Polished Graphite

**QB:** Antique Brass

**SB:** Satin Brass

**SC:** Satin Chrome

**SN:** Satin Nickel

#### *Signature Metal Finishes*

**GP:** Graphite

#### *Glass Finish*

**CBL:** Clear Black Glass

**CWH:** Clear White Glass

### Field Changes

#### *Button engraving changes*

Any keypad can have its buttons swapped in the field to change the engraving (e.g., 2-Button swapped for engraved 2-Button).

#### *Button configuration changes*

For easy system configuration changes, a 3-Button with Raise/Lower may be swapped in the field for a 4-Button.

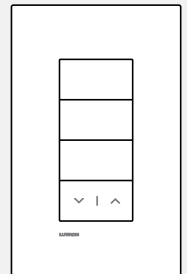
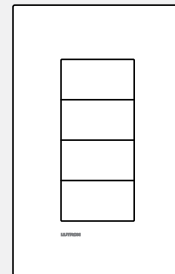

|  |                       |
|--|-----------------------|
| <b>Job Name:</b><br><br><b>Job Number:</b> | <b>Model Numbers:</b> |
|--|-----------------------|



## How to Build a Model Number *(continued)*

### Faceplate Kits

Use Faceplate Kits to change color and ganging. Each Faceplate Kit includes a faceplate adapter and faceplate.

**LWT – U – P – WH**

#### Family

**LWT:** Palladiom  
Faceplate Kit

#### Faceplate Options

**U:** U.S. Style

**S:** Square Style

#### Gangs\* and Openings

**P\*\*:** Palladiom Keypad

#### Colors and Finishes

Colors and Finishes for buttons and faceplates must always match (e.g., matte plastic buttons with matte plastic faceplate, metal buttons with metal faceplate).

##### *Architectural Matte Finishes*

**AL:** Almond

**BE:** Beige

**BL:** Black

**BR:** Brown

**GR:** Gray

**IV:** Ivory

**LA:** Light Almond

**SI:** Sienna

**TP:** Taupe

**WH:** White

##### *Architectural Metal Finishes*

**BB:** Bright Brass

**BC:** Bright Chrome

**BN:** Bright Nickel

**PG:** Polished Graphite

**QB:** Antique Brass

**SB:** Satin Brass

**SC:** Satin Chrome

**SN:** Satin Nickel

##### *Signature Metal Finishes*

**GP:** Graphite

##### *Glass Finish*

**CBL:** Clear Black Glass

**CWH:** Clear White Glass

\* Palladiom Keypads do not gang with other devices of different sizes (e.g., Maestro or GRAFIK T controls).

\*\* Repeat the letter designation "P" (4 maximum) for each opening (e.g., 1-gang = P, 2-gang = PP). See How to Select a Palladiom Keypad.

|  |                              |
|--|------------------------------|
| <p><b>Job Name:</b></p><br><p><b>Job Number:</b></p> | <p><b>Model Numbers:</b></p> |
|--|------------------------------|

## Engraving Options

The Palladiom Keypad has engraving options ideal for many scenarios. The following information will help you determine which engraving option is best-suited to your needs.

### Predefined Custom Engraving

Predefined project engraving is for instances when the customer knows the engraving details at the time of purchase and does not wish to order two sets of button kits. To select this option, use engraving option “E” when ordering the keypad.

**Note: Orders cannot be processed until engraving information is received.**

### Generic Engraving and Post-Defined Custom Engraving

When engraving details are not known or specified at the time an order is placed, the generic engraving icons shown below will be sent to provide the customer with a usable keypad until the custom engraving details are determined. This keypad will be shipped with an engraving credit for ordering a custom-engraved button kit at a later time.

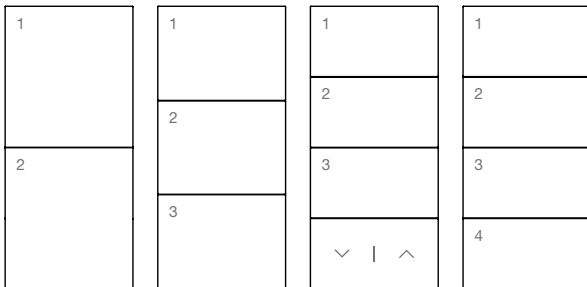

|  |                              |
|--|------------------------------|
| <p><b>Job Name:</b></p><br><p><b>Job Number:</b></p> | <p><b>Model Numbers:</b></p> |
|--|------------------------------|

# How to Select a Palladiom Keypad

Examples of keypad and faceplate configurations are shown below.

## U.S. Style

| Model Number         | Quantity | Assembled | Mount        |
|----------------------|----------|-----------|--------------|
| <b>1-Gang Keypad</b> |          |           |              |
| QWP-U-4W-WH          | 1        | Yes       | U.S. Wallbox |

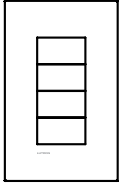

| Model Number         | Quantity | Assembled | Mount        |
|----------------------|----------|-----------|--------------|
| <b>2-Gang Keypad</b> |          |           |              |
| QWP-B-4W-WH          | 2        | No*       | U.S. Wallbox |
| LWT-U-PP-WH          | 1        |           |              |

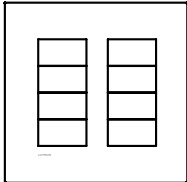

| Model Number         | Quantity | Assembled | Mount        |
|----------------------|----------|-----------|--------------|
| <b>3-Gang Keypad</b> |          |           |              |
| QWP-B-4W-WH          | 3        | No*       | U.S. Wallbox |
| LWT-U-PPP-WH         | 1        |           |              |

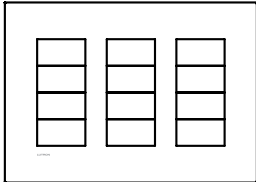

| Model Number         | Quantity | Assembled | Mount        |
|----------------------|----------|-----------|--------------|
| <b>4-Gang Keypad</b> |          |           |              |
| QWP-B-2W-WH          | 4        | No*       | U.S. Wallbox |
| LWT-U-PPPP-WH        | 1        |           |              |

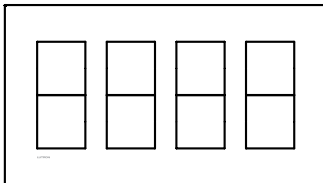

## Square Style

| Model Number           | Quantity | Assembled | Mount                   |
|------------------------|----------|-----------|-------------------------|
| <b>1-Column Keypad</b> |          |           |                         |
| QWP-S-4W-WH            | 1        | Yes       | Square or Round Wallbox |

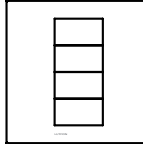

| Model Number           | Quantity | Assembled | Mount                   |
|------------------------|----------|-----------|-------------------------|
| <b>2-Column Keypad</b> |          |           |                         |
| QWP-S-24W-WH           | 1        | Yes       | Square or Round Wallbox |

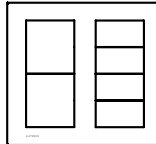

3-button configuration not available.

| Model Number           | Quantity | Assembled | Mount      |
|------------------------|----------|-----------|------------|
| <b>3-Column Keypad</b> |          |           |            |
| QWP-B-4W-WH            | 3        | No*       | EBB-1-3COL |
| LWT-S-PPP-WH           | 1        |           |            |

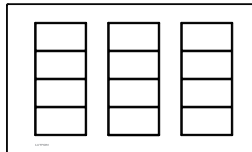

| Model Number           | Quantity | Assembled | Mount                       |
|------------------------|----------|-----------|-----------------------------|
| <b>4-Column Keypad</b> |          |           |                             |
| QWP-B-44W-WH           | 1        | No*       | 2 Square or Round Wallboxes |
| QWP-B-22W-WH           | 1        |           |                             |
| LWT-S-PPPP-WH          | 1        |           |                             |

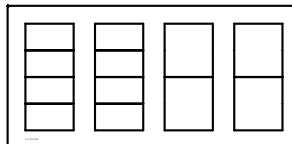

3-button configuration not available.

\* Model numbers must be ordered as separate pieces and assembled. See Keypad Assembly.

|             |                |
|-------------|----------------|
| Job Name:   | Model Numbers: |
| Job Number: |                |

# Keypad Assembly

Tools Required: Phillips head screwdriver (not included)

1. Place button kit on back of faceplate.
2. Align bulk unit over button kit and faceplate.
3. Assemble using 4 screws (provided).
4. Repeat steps 1–3 for each base unit.

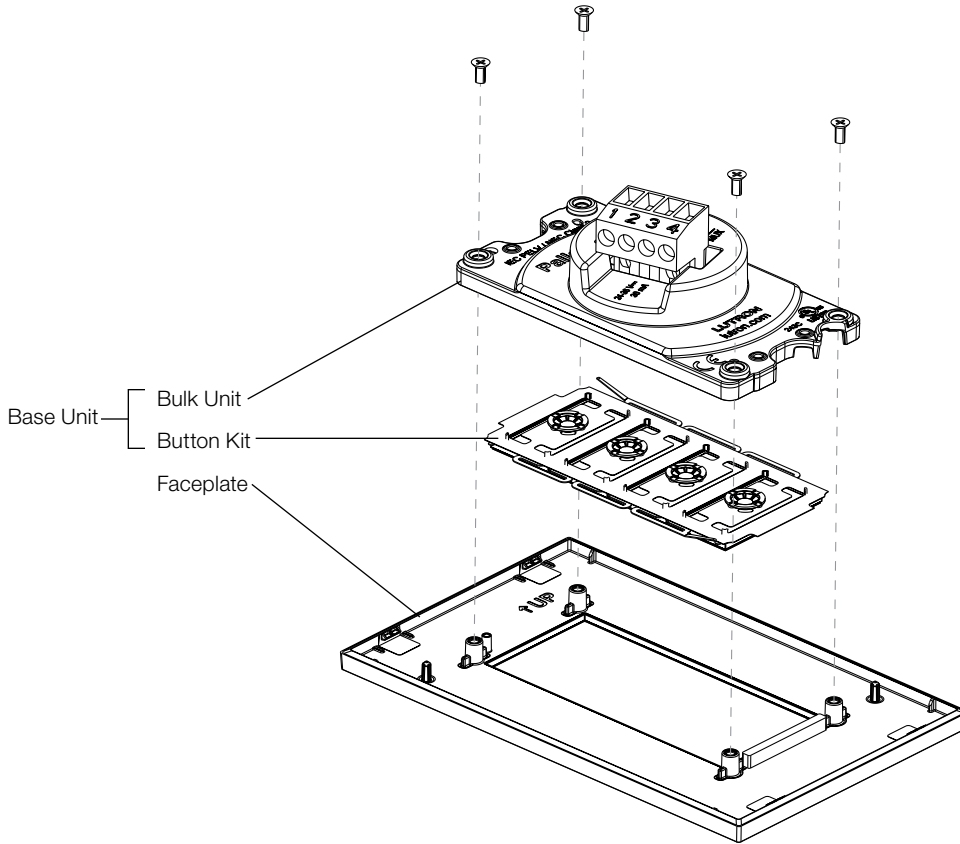

|             |                |
|-------------|----------------|
| Job Name:   | Model Numbers: |
| Job Number: |                |

# Mounting

## U.S. Style

### 1-Gang

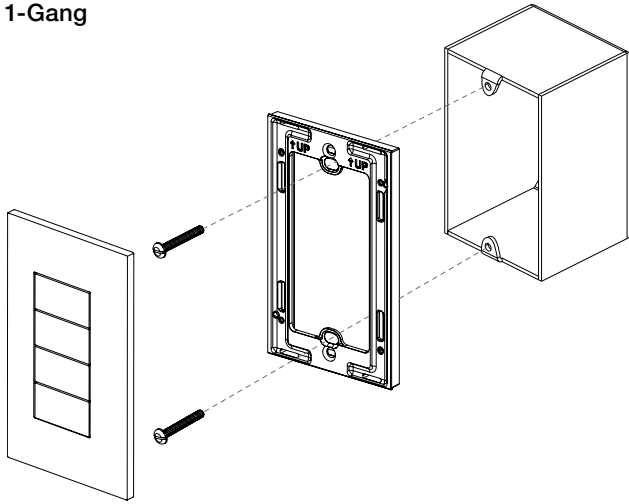

Back View

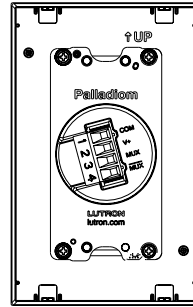

### 2-Gang

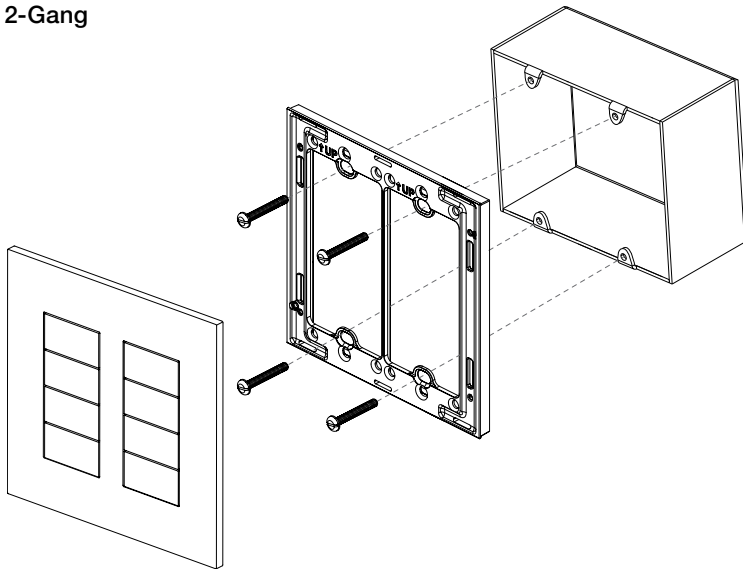

Back View

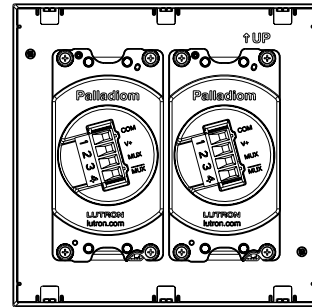

(continued on next page...)

|  |                       |
|--|-----------------------|
| <p>Job Name:</p><br><p>Job Number:</p> | <p>Model Numbers:</p> |
|--|-----------------------|

# Mounting *(continued)*

## U.S. Style *(continued)*

### 3-Gang

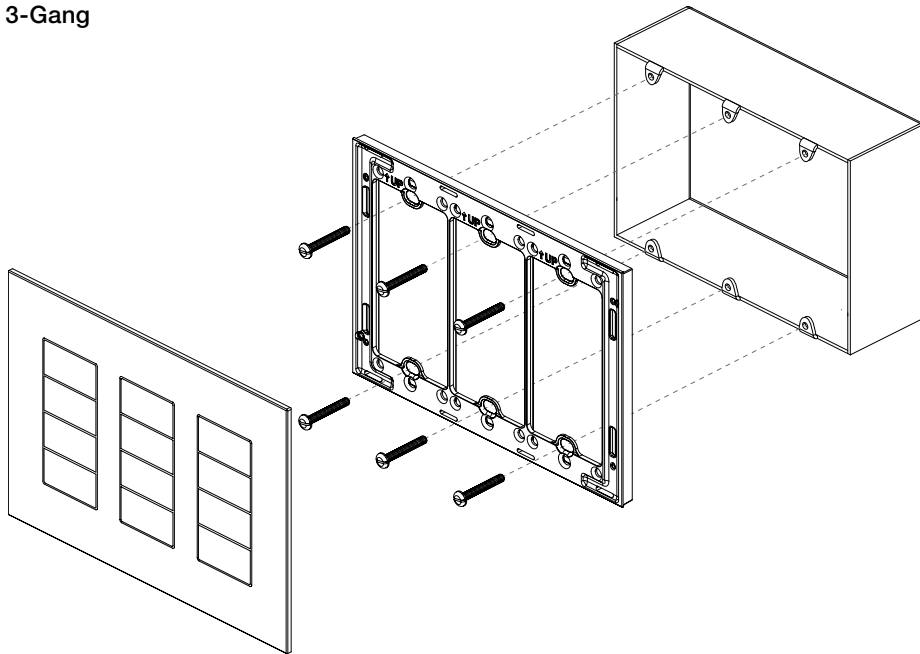

Back View

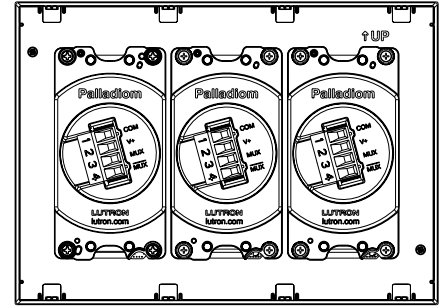

### 4-Gang

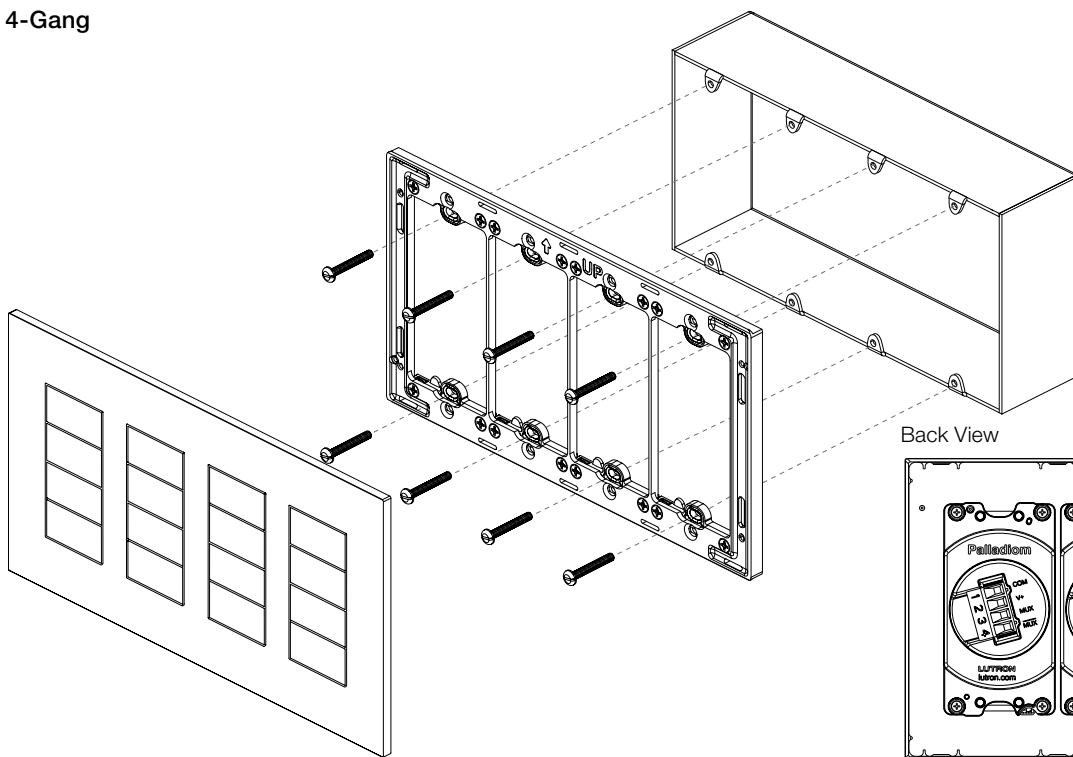

Back View

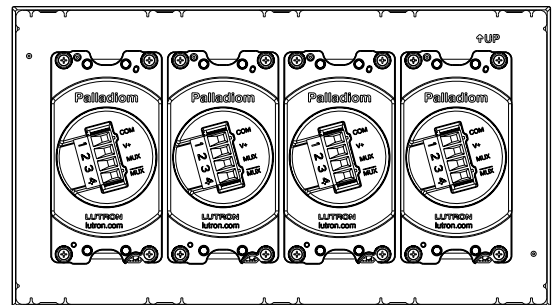

(continued on next page...)

|  |                       |
|--|-----------------------|
| <p>Job Name:</p><br><br><p>Job Number:</p> | <p>Model Numbers:</p> |
|--|-----------------------|

### Mounting *(continued)*

#### Square Style (Square or Round Wallbox\*)

##### 1-Column

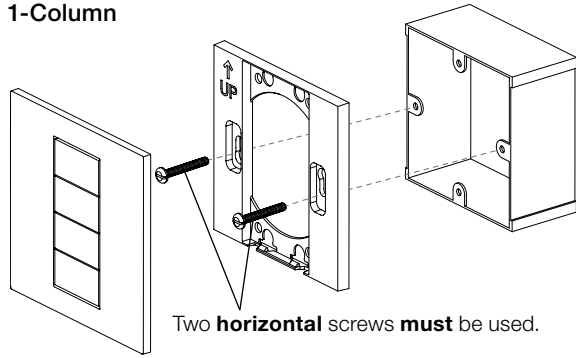

Back View

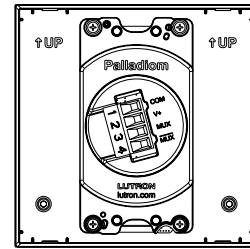

##### 2-Column

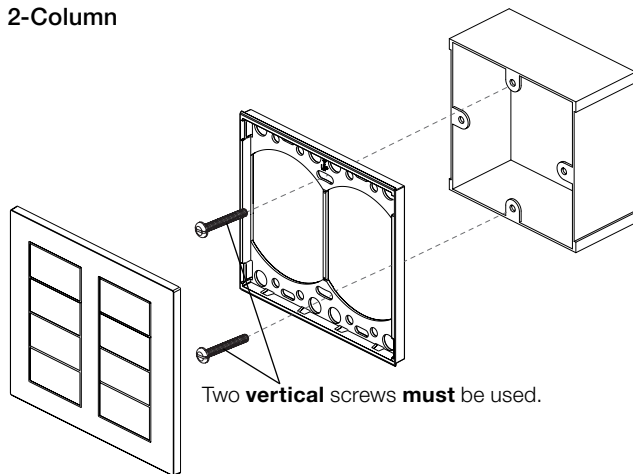

Back View

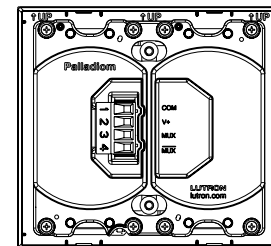

**Note:** 2-column base unit shown with 2-column faceplate. 1 + 1 keypad configuration will not fit with a U.K. or European backbox.

\* Use wallbox with 4 available mounting screw holes for maximum flexibility.

|  |                       |
|--|-----------------------|
| <p>Job Name:</p><br><br><p>Job Number:</p> | <p>Model Numbers:</p> |
|--|-----------------------|

## Mounting *(continued)*

### Square Style (Square or Round Wallbox) *(continued)*

#### 3-Column<sup>1,2</sup>

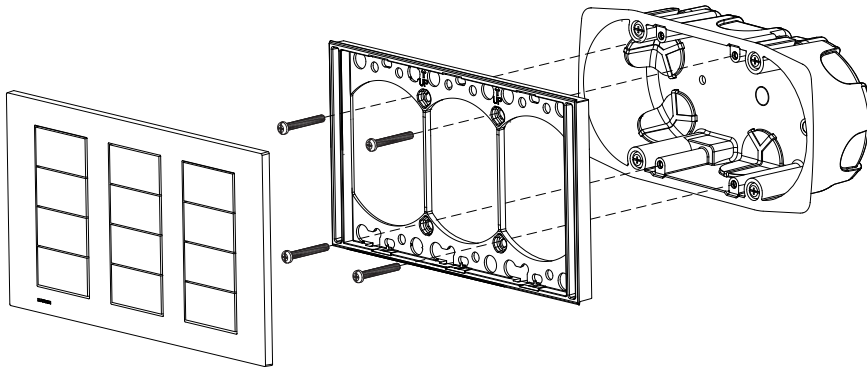

Back View

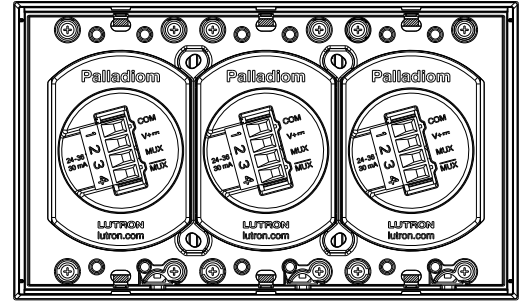

<sup>1</sup> Use Lutron part number EBB-1-3COL as wallbox for 3-Column wall installations.

<sup>2</sup> EBB-1-3COL is for hollow wall or plaster installations. Do not use for concrete pour installations. See Lutron App Note #705 (P/N 048705) at [www.lutron.com](http://www.lutron.com) for installation instructions.

#### 4-Column\*

Measurements shown as: mm (in)

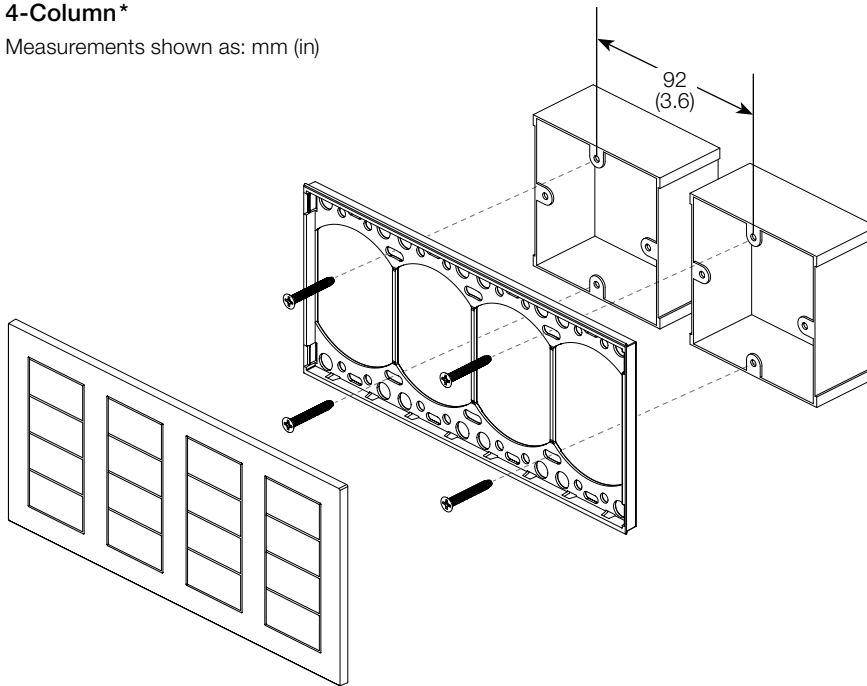

Back View

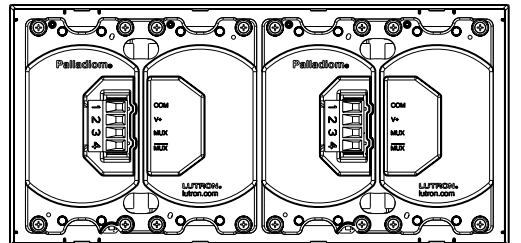

**Note:** Two 2-column keypads shown. Four 1-column keypads cannot mount to a wallbox.

\* Use wallbox with 4 available mounting screw holes for maximum flexibility.

|             |                |
|-------------|----------------|
| Job Name:   | Model Numbers: |
| Job Number: |                |



## QS Link Wiring

- Use SELV/PELV/NEC® Class 2 wiring to connect keypads to the QS link.
- Connect two 22 AWG (0.5 mm<sup>2</sup>) shielded, twisted pairs of wires to terminals 3 and 4 of the keypad control link connector. Shielding (drain) of the twisted-pair wires must be connected together as shown, but do not connect the shielding to earth/ground or to the keypad and do not allow the shielding to contact the grounded wallbox.
- Connect the appropriate size wires to terminals 1 and 2 for power according to your link length (see table below).

**Note:** Use appropriate wire connecting devices as specified by local codes.

- Each base unit model number counts as 1 device on the QS link.
- Each button column of a QS wired Palladiom Keypad consumes 1 power draw unit (PDU) on the QS link. For complete information, see “Power Draw Units on the QS Link” (Lutron P/N 369405) at [www.lutron.com](http://www.lutron.com)

### QS Link Wire Sizes (check compatibility in your area)

| QS Link Wiring Length              | Wire Gauge   | Lutron Cable Model Number |
|------------------------------------|--|---------------------------|
| Less than 500 ft (153 m)           | Power (terminals 1, 2): 1 pair 18 AWG (1.0 mm <sup>2</sup> )   | GRX-CBL-346S (non-plenum) |
|                                    | Data (terminals 3, 4): 1 shielded, twisted pair 18 AWG to 22 AWG (1.0 mm <sup>2</sup> to 0.5 mm <sup>2</sup> ) | GRX-PCBL-346S (plenum)    |
| 500 ft to 2000 ft (153 m to 610 m) | Power (terminals 1, 2): 1 pair 12 AWG (4.0 mm <sup>2</sup> )   | GRX-CBL-46L (non-plenum)  |
|                                    | Data (terminals 3, 4): 1 shielded, twisted pair 18 AWG to 22 AWG (1.0 mm <sup>2</sup> to 0.5 mm <sup>2</sup> ) | GRX-PCBL-46L (plenum)     |

#### Link Wiring less than 500 ft (153 m)

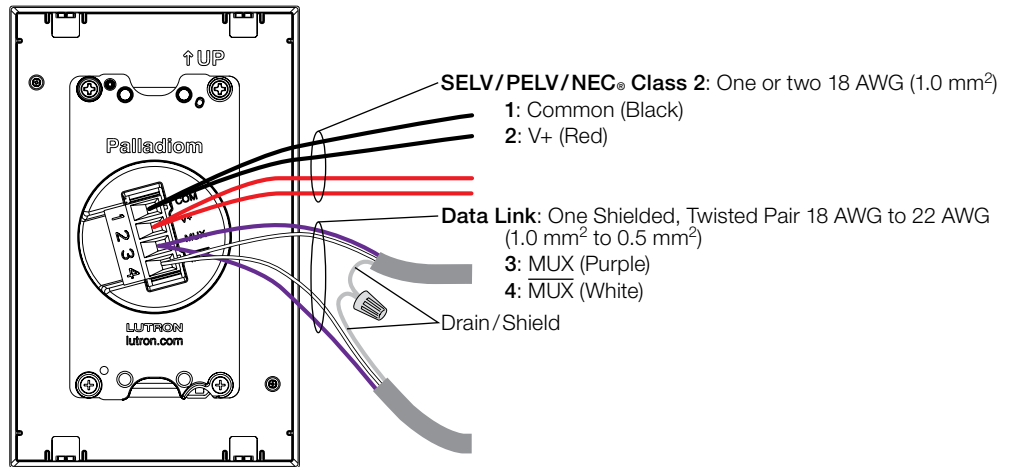

#### Link Wiring 500 ft to 2000 ft (153 m to 610 m)

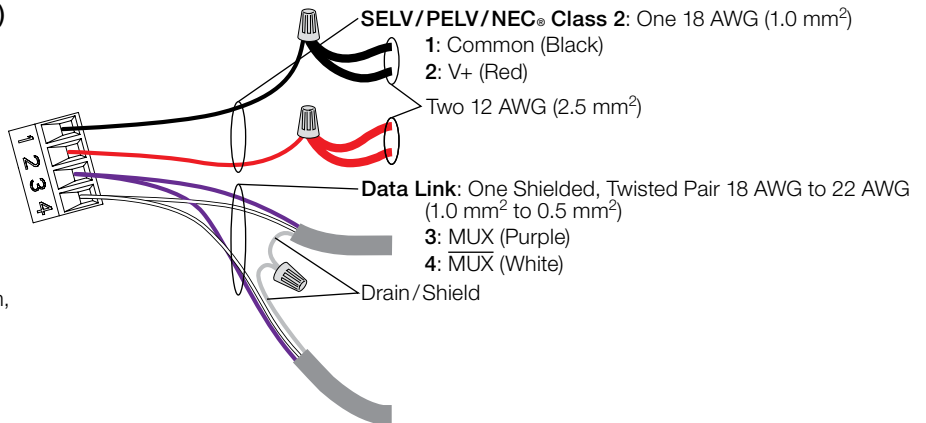

The Lutron logo, Lutron, GRAFIK T, Maestro, myRoom, Palladiom and Quantum are trademarks or registered trademarks of Lutron Electronics Co., Inc. in the US and/or other countries.

|                    |                       |
|--------------------|-----------------------|
| <b>Job Name:</b>   | <b>Model Numbers:</b> |
| <b>Job Number:</b> |                       |