

LCP128 Dimming and Switching System

System Overview

LCP128 is a combination dimming and switching system that provides a complete lighting control solution. The system consists of panels and control station devices. An integrated astronomical time clock provides system automation capability.

System Features

- 32 programmable lighting scenes and off. System is capable of more than 32 scenes if custom scenes are used.
- Connect up to 8 power panels for up to 128 dimmed/switched outputs.
- Connect up to 32 wallstations or control devices for multiple points of control.
- Entire system is programmed using the LCD controller mounted in the panel.
- Astronomical time clock provides automated selection of lighting scenes.
- Works directly with incandescent, magnetic low-voltage, reverse-phase electronic low-voltage, neon, Lutron Tu-Wire and switched load types.
- Works with DSI, DALI®, and 0-10 V_{ac} dimming ballasts using 10 V_{ac} modules in the panel.
- Works with Lutron Eco-10 and Hi-lume Fluorescent Dimming Ballasts.
- Fan and motor modules are also available
- Feed-through or branch circuit breaker panels are available.
- Panel is pre-wired and pre-tested.
- Standard-size and mini panels may be surface or recess mounted between 16 in (40 cm) center-to-center studs.



LCP128 standard panel

<p>Job Name:</p> <p>Job Number:</p>	<p>Model Numbers:</p>
--	------------------------------

LCP128 Controller

Overview

Lighting control may be automated by using the astronomical time clock integrated into the LCP128 controller. The controller has an LCD screen for easy programming.

Features

- LCD interface simplifies scene, time clock event, and control station programming.
- Time clock events automatically recall presets at a specific time of day or at an offset from sunrise or sunset.
- Up to 500 total events are programmable within 7 daily schedules and 40 holiday schedules.
- Holiday schedules are programmable to run once or repeat up to 90 days in a row.
- Two integrated contact closure inputs provide an interface with occupancy sensors or building management systems.
- Select system location from a built-in city database or by entering latitude and longitude.
- Time clock is battery backed; time and event settings are remembered even after power failures.
- California Energy Commission Title 24 listed with programmable flash-warn feature.



LCP128 Controller

Job Name:	Model Numbers:
Job Number:	

Module Specifications

1, 2 and 4 Output Dimming Modules (LP-RPM-4U-120, LP-RPM-2U-120, LP-RPM-1U-120)

Load Types

Incandescent; Magnetic low-voltage; Neon/cold cathode; Lutron Tu-Wire fluorescent dimming ballast; Lutron Hi-lume and Eco-10 fluorescent dimming ballasts (using PHPM-3F-120-WH interface)

Outputs are compatible with Lutron PHPM-PA-120-WH for higher wattage applications

Maximum Load

20 A branch circuit:

- 16 A continuous total load per module

- 16 A continuous total load per switch leg

15 A branch circuit:

- 12 A continuous total load per module

- 12 A continuous total load per switch leg

4-Output Adaptive Dimming Module (LP-RPM-4A-120)

Load Types

Incandescent; Magnetic low-voltage; Electronic low-voltage; Neon/cold cathode; Lutron Tu-Wire fluorescent dimming ballast; fluorescent dimming ballast

Maximum Load

20 A branch circuit:

- 16 A continuous total load per module

- 10 A continuous total load per switch leg

15 A branch circuit:

- 12 A continuous total load per module

- 10 A continuous total load per switch leg

4-Output Switching Module (120 – 347 V~) (XP2)

Load Types

Non-dim loads

Maximum Load

20 A branch circuit:

- 16 A continuous total load per circuit

- 1/2 HP total load per switch leg

15 A branch circuit:

- 12 A continuous total load per circuit

- 1/2 HP total load per switch leg

Continued on next page...

Job Name:	Model Numbers:
Job Number:	

Module Specifications *(continued)***4-Output Quiet Fan Speed Control Module (LP-RPM-4FSQ-120)****Load Types**

Ceiling fan

Maximum Load

2 A (single ceiling fan) per output

4-Output Motor Module (LP-RPM-4M-120)**Load Types**

Bi-directional 3-wire 120 V~ motor loads; incandescent non-dim loads

*Outputs are not rated for switching electronic low-voltage or electronic ballasts***Maximum Load**

20 A branch circuit:

1/4 HP per circuit

5 A maximum per circuit for motor loads

3 A maximum per circuit for tungsten loads

Job Name:	Model Numbers:
Job Number:	

Specifications

Standards

- UL® Listed (Reference: UL File E42071)
- CSA Certified
- California Energy Commission Listed
- Seismic Certified (Test Method AC156. Reference OSHPD Preapproval OSP-0215-10)
- NOM certified models available
- CE models available
- Other certificates may apply

Power

- Input power: 100-127 V~ phase-to-neutral.
- Branch Circuit Capacity:
 - 120-127 V~: up to 2000 W/VA
- Branch circuit breakers (if applicable): UL-rated thermal magnetic. AIC rating:
 - 100-127 V~: 10,000 A

NOTE: See page 6 for SCCR ratings.

- Lightning strike protection: meets ANSI/IEEE standard 62.41-1980. Can withstand surges of up to 6000 V~ and up to 3000 A.
- 10-year power failure memory: automatically restores lighting to scene selected prior to power interruption.
- RTISS filter circuit technology compensates for incoming line voltage variations: no visible flicker with +/-2% change in RMS voltage/cycle and +/-2% Hz change in frequency/second.
- Softswitch arcless relay technology featured in every 16 A switched circuit.

Lighting Sources/Load Types

Operates these sources with a smooth continuous Square Law dimming curve or on a full conduction non-dim basis:

- Incandescent (tungsten)/halogen
- Magnetic low-voltage transformer
- Lutron Tu-Wire
- Neon
- HID (full-conduction non-dimbasis only)

- Switched lighting loads
- DSI, DALI®, and 0-10 V⁼⁼ dimming ballasts using 10 V⁼⁼ modules in the panel
- Fan
- Motor
- Electronic low-voltage transformer
- Lutron Hi-lume and Eco-10 fluorescent dimming ballasts are controlled or via power interfaces

Physical Design

- Enclosure: NEMA-Type 1, IP-20 protection (Type 2 available upon request); 16 U.S. gauge steel. Indoor use only.
- Panel weight:
 - Mini: 30 lb (14 kg)
 - Standard-size: 80 lb (37 kg)
- Seismic Certification Limits: $S_{DS}=2.5$ g, $z/h=1.0$, $I_p=1.5$. Panels containing fan or motor control modules are limited to $S_{DS}=1.5$ g. Contact Lutron for details.

Mounting

- Mini and standard-size panels surface mount or recess mount between 16 in (40 cm) studs.

Environment

- 32 °F to 104 °F (0 °C to 40 °C).
- Relative humidity less than 90% non-condensing.

Heat Dissipation

- Panels cool by convection. No fans.

Wiring

- Internal: prewired by Lutron.
- System communications: low-voltage IEC PELV/ NEC® Class 2 wiring connects dimming panels to other components.
- Line (mains) voltage: feed and load wiring only. No other wiring or assembly required.

Continued on next page...

<p>Job Name:</p> <p>Job Number:</p>	<p>Model Numbers:</p>
--	------------------------------

Specifications *(continued)*

LCP128 Controller

- Configures entire LCP128 system.
- Two low-voltage (15–24 V_{AC}) contact closure inputs, momentary or maintained, pull-up or pull-down.
- Emergency sensing.
- Astronomical time clock.
- Digital control link.
- Mounted inside LCP128 panel.
- For commercial use, Class A only.

Dimming Modules (mini and standard-size panels)

4-Output Dimming Modules:

- Each dimming module can control a fully loaded electrical circuit (16 A maximum), with four dimming outputs per Module.

2-Output Dimming Modules:

- Each dimming module can control a fully loaded electrical circuit (16 A maximum), with two dimming outputs per module.

1-Output Dimming Modules:

- Each dimming module can control a fully loaded electrical circuit (16 A maximum), with one dimming output per module.

All Module Types:

- Single output and/or all outputs combined not to exceed 16 A per module.

Switching Modules (mini and standard-size panels)

- 4 switched circuits (relays) per module.
- Softswitch relay is rated for 16 A continuous use, which is the maximum continuous load for a 20 A overcurrent protection device (branch breaker).
- Patented Softswitch circuit eliminates arcing at mechanical contacts when loads are switched. Extends relay life to an average of 1,000,000 cycles (on/off) for resistive, capacitive or inductive sources.
- Relay is mechanically held.

Astronomical Time Clock

- Capable of up to 500 events.
- 7 daily schedules and 40 holiday schedules are available.
- 25 events per day.
- Holiday events are programmable one year in advance.
- Holiday schedules are programmable to run for up to 90 days.
- ATC location programmable by built-in city database or by entering latitude and longitude, plus a sunrise or sunset offset to adjust for local geography.

Control Station Devices

- One- to seven-button seeTouch wallstations.
- Buttons are programmable to select scenes or patterns, toggle circuits, or activate delay-to-off.
- Buttons are programmed at the LCP128 controller.
- Key switch control is also available.
- Controls are powered by and communicate via the LCP128 low-voltage communication link.
- OMX-IO interfaces with occupant or photo sensors.
- OMX-CI-RS232 interfaces the LCP128 system to a PC, touchscreen, or building management system.
- See specific product specification sheets for further details.

LCP Panels Short Circuit Current Ratings (other ratings available)

Panel Type	V _~	Standard SCCR Rating
LCP Main Lug Panels (all sizes)	120	25,000 A
LCP Feed-Through Panels (all sizes)	120	25,000 A

Job Name:	Model Numbers:
Job Number:	

seeTouch Wallstations

Description

- Each seeTouch wallstation features engraved, backlit buttons allowing quick and easy recall of lighting presets, even in low light conditions.
- Button functionality is fully programmable.

Specifications

- Low-voltage type IEC PELV/NEC® Class 2
Operating voltage: 24 V^{DC}.
- Meets IEC 801-2. Tested to withstand 15 kV electrostatic discharge without damage or memory loss.
- Faceplate snaps on with no visible means of attachment.
- Terminals accept up to two 18 AWG (0.75 mm²) wires typical.
- Environment: 32 °F to 104 °F (0 °C to 40 °C).
Relative humidity less than 90% non-condensing.

seeTouch Models

- Models available with one to seven buttons, with or without raise/lower.
- Use SO series model numbers.
- Available with all standard colors and engraving.
- Available with built-in contact closure inputs or with optional occupant sensor inputs.

Button Programming

- Each button may be programmed for scene selection, toggle, delay-to-off, raise, or lower functionality.
- Button programming can be used to provide specialized manual control of multiple areas.

Button Engraving

Custom engraving is available using button/faceplate replacement kits. To order, contact Lutron Customer Assistance at 1.844.LUTRON1 (1.844.588.7661).

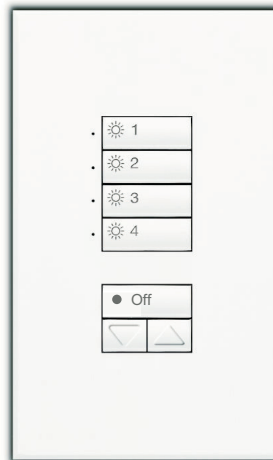

seeTouch Wallstation
(SO-4SN-WH-EGN)

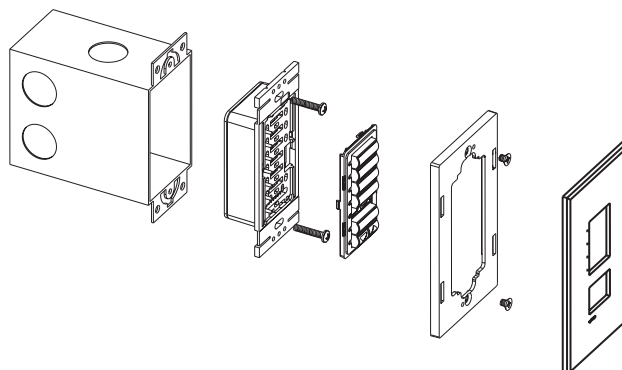

Typical wallbox dimensions: 3.74 in (95 mm) high, 2.17 in (55 mm) wide, 2.75 in (70 mm) deep.

Job Name:	Model Numbers:
Job Number:	

LCP Panel Model Numbers: Mini and Standard-Size

Example

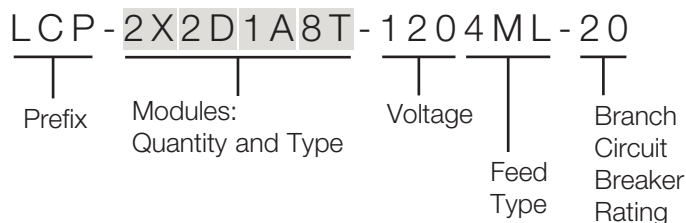

Prefix

LCP = LCP dimming panel

Module Types

X S D Q A E M F T

List modules in the order shown above. Insert the quantity before each module code. Omit codes for modules not used in panel. See Note at right for limits on numbers of modules per panel.

X = Four-Circuit Switching (Relay) (XP)

S = One-Circuit Dimming (1U)

D = Two-Circuit Dimming (2U)

Q = Four-Circuit Dimming (4U)

A = Four-Circuit Adaptive Dimming (4A)

M = Four-Circuit Motor (4M)

F = Four-Circuit Quiet Fan Speed (4FSQ)

T = 0–10 V_{DC} Ballast Control (TVM)

Voltage

120 = 120 V_{AC}

Feed Type

FT = Feed-through panel (circuit breakers not included)

3M or 3ML = 1 phase 3 wire feed (split phase)

4M or 4ML = 3 phase 4 wire feed

Branch Circuit Breaker Rating

Omit for feed-through panels

20 = 20 A branch circuit breakers

Frequency – All Model Numbers and Voltages

50/60 Hz

Output (Load) Ratings

Module Type	Rating
XP	16 A per circuit
1U, 2U, 4U	16 A per module
4A	16 A per module, 10 A per output
4M	16 A per module, 5 A per output (1/4 HP single motor)
4FSQ	2 A per output (single ceiling fan)
TVM	50 mA per channel, 750 mA per system

NOTE

Module quantities are limited as follows:

Standard-Size Branch Circuit Breaker panels

Max. # in panel: 9

Max. # with TVM modules: 8

Max. # with XP modules: 7

Max. # with XP and TVM modules: 5

Standard-Size Feed-Through panels

Max. # in panel: 9

Max. # with TVM modules: 8

Mini-Size Branch Circuit Breaker panels

(no XP modules):

Max. # in panel: 3

Mini-Size Feed-Through panels

Max. # in panel (with XP modules): 3

Max. # in panel (all XP modules): 4

Input Ratings

120 V_{AC}

120/240 V_{AC}

120/208 V_{AC}

Job Name:	Model Numbers:
Job Number:	

Ratings: Mini and Standard-Size

LCP128 panels with circuit breakers, no XP switching modules (standard panels, main lugs only)

Number of Modules	Feed Type	Feed Size (A)	Breaker Ratings	Panel Size
2	1Ø, 3 W	20 A	20 A	Mini
3	3Ø, 4 W	20 A	20 A	Mini
4	3Ø, 4 W or 1Ø, 3 W	175 A	20 A	Standard
5	3Ø, 4 W or 1Ø, 3 W	175 A	20 A	Standard
6	3Ø, 4 W or 1Ø, 3 W	175 A	20 A	Standard
7	3Ø, 4 W or 1Ø, 3 W	175 A	20 A	Standard
8	3Ø, 4 W or 1Ø, 3 W	175 A	20 A	Standard
9	3Ø, 4 W or 1Ø, 3 W	175 A	20 A	Standard

LCP128 panels with circuit breakers, with XP switching modules (standard panels, main lugs only)

Number of Modules	Feed Type	Feed Size (A)	Breaker Ratings	Panel Size
2	3Ø, 4 W or 1Ø, 3 W	200 A	20 A	Standard
3	3Ø, 4 W or 1Ø, 3 W	200 A	20 A	Standard
4	3Ø, 4 W or 1Ø, 3 W	200 A	20 A	Standard
5	3Ø, 4 W or 1Ø, 3 W	200 A	20 A	Standard
6	3Ø, 4 W or 1Ø, 3 W	200 A	20 A	Standard
7	3Ø, 4 W or 1Ø, 3 W	175 A	20 A	Standard

Note: Refer to the **How to Build a Model Number** section for a listing of available module types.

Continued on next page...

Job Name:	Model Numbers:
Job Number:	

Ratings: Mini and Standard-Size *(continued)*

Feed-through LCP128 panels, with XP Switching Modules (without branch circuit breakers)

Number of Modules	Feed Type	Feed Size (A)	Panel Size
2	1Ø, 2 W	20 A	Mini
3	1Ø, 2 W	20 A	Mini
4	1Ø, 2 W	175 A	Standard
5	1Ø, 2 W	175 A	Standard
6	1Ø, 2 W	175 A	Standard
7	1Ø, 2 W	175 A	Standard
8	1Ø, 2 W	175 A	Standard
9	1Ø, 2 W	175 A	Standard

Feed-through LCP128 panels, XP Switching Modules Only (without branch circuit breakers)

Number of Modules	Feed Type	Feed Size (A)	Panel Size
2	1Ø, 2 W	20 A	Mini
3	1Ø, 2 W	20 A	Mini
4	1Ø, 2 W	175 A	Mini
5	1Ø, 2 W	175 A	Standard
6	1Ø, 2 W	175 A	Standard
7	1Ø, 2 W	175 A	Standard
8	1Ø, 2 W	175 A	Standard
9	1Ø, 2 W	175 A	Standard

Note: Refer to the **How to Build a Model Number** section for a listing of available module types.

Job Name:	Model Numbers:
Job Number:	

Mini Panel Dimensions

Dimensions shown as: in (mm).

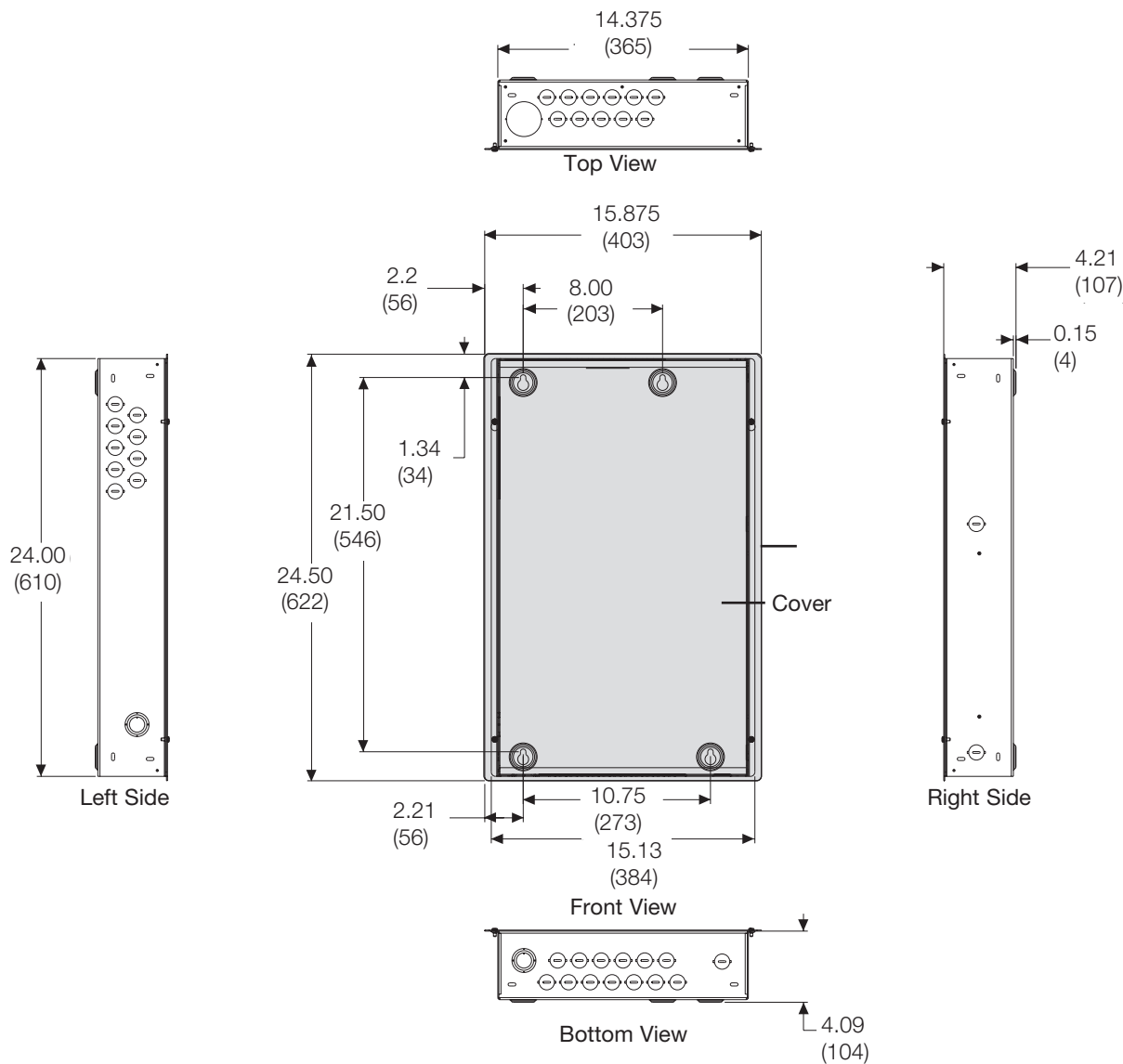

Job Name:	Model Numbers:
Job Number:	

Standard-Size Panel Dimensions

Dimensions shown as: in (mm).

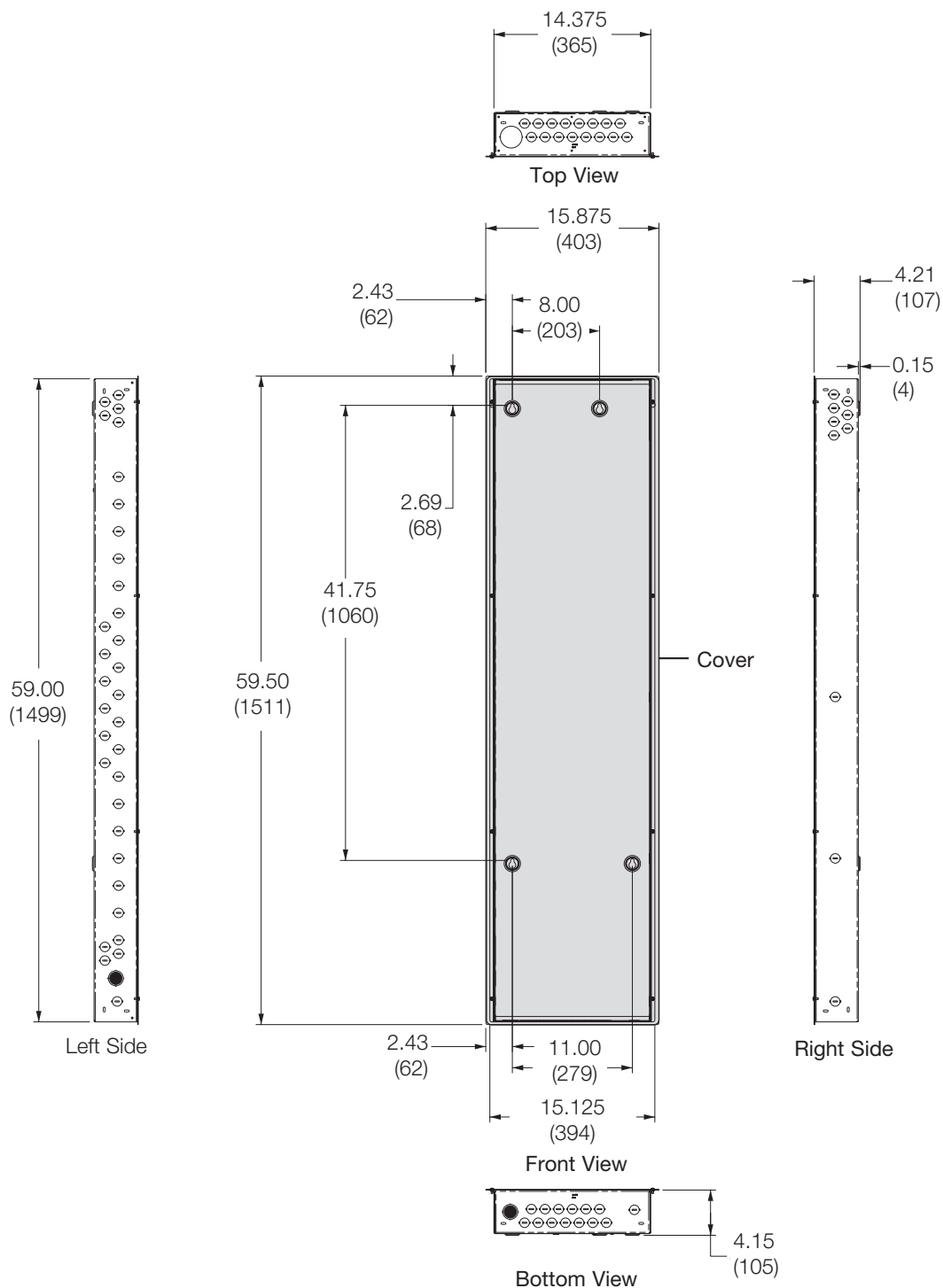

Job Name:	Model Numbers:
Job Number:	

Panel Mounting: Mini and Standard-Size

- Panel generates heat. Mount only where ambient temperature will be 32 °F to 104 °F (0 °C to 40 °C).
- Reinforce wall structure as required for weight and local codes.
- Allow 12 in (305 mm) clearance above and below panel.
- Indoor use only. NEMA®, Type 1 enclosure, IP20.
- Relative humidity must be < 90% non-condensing.
- Mount panels within 7° of true vertical.
- Install in accordance with all national and local electrical codes.

NOTICE: Dimming panels will hum slightly and internal relays will click while in operation. Mount where audible noise is acceptable.

NOTICE: Mount panel so line (mains) voltage wiring will be at least 6 ft (1.8 m) from sound or electronic equipment and wiring.

NOTICE: This equipment is air-cooled. Vents must not be blocked or the warranty will be voided.

Surface Mounting

- Lutron recommends using 1/4 in (6 mm) mounting bolts (maximum size accepted by keyholes).
- Reinforce wall structure as required for weight and local codes.
- Do not mount panel directly to wall board/drywall.

Recess Mounting

- Mount to wall stud by screwing through slots in corners of panel.
- Mount panel between flush and 1/8 in (3 mm) below finished wall surface.

Recommended Mounting Heights* (for LCP128 systems)

Mini	45 in (1143 mm)
Standard	25 in (635 mm)

* Measure from floor to bottom of panel; optimal viewing height for controller.

Number of Modules	Maximum Heat BTUs (Kcal)/H
1	90 (22.68)
2	170 (42.84)
3	250 (63.00)
4	330 (83.16)
5	410 (103.32)
6	490 (123.48)
7	570 (143.64)
8	650 (163.80)
9	730 (183.96)

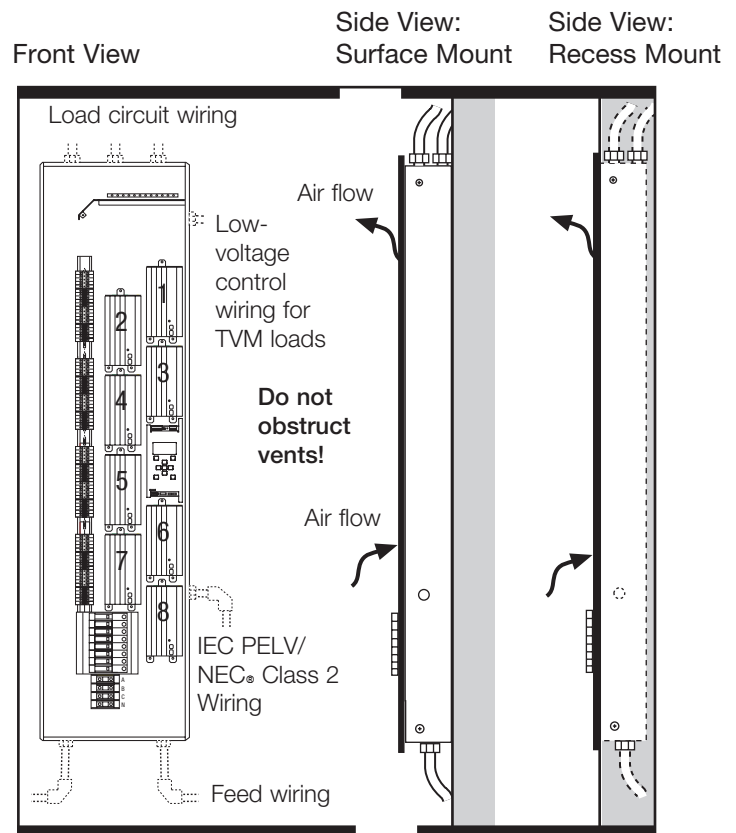

LP8/32-1204ML-20 shown

Job Name:	Model Numbers:
Job Number:	

Feed Wiring Details: 120 V~ Mini and Standard-Size Main Lug

Dimming and Switching Panels

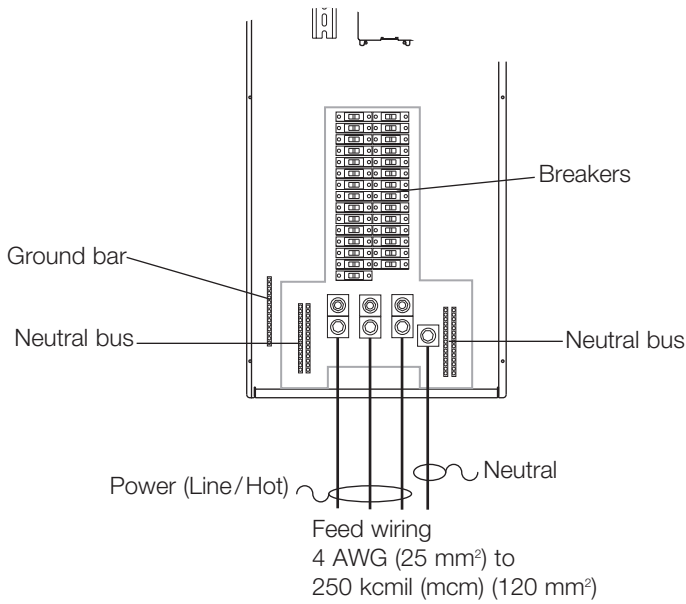

Wire Sizes for Load Wiring (All Models)

- Dimmed/Switched Line/Hot (Live):
14 AWG (2.5 mm²) to 10 AWG (4.0 mm²)
- Load Neutral:
14 AWG (2.5 mm²) to 10 AWG (4.0 mm²)

NOTES

- See *Feed and Load Wiring to Terminal Blocks* page for load wiring details.
- On dimming panels only, the input breaker of Circuit 1 supplies current to Load Circuit 1 and to the Control Wiring (2 A draw maximum). Panels with switching modules have a dedicated circuit breaker for the control circuit.

Dimming Panels

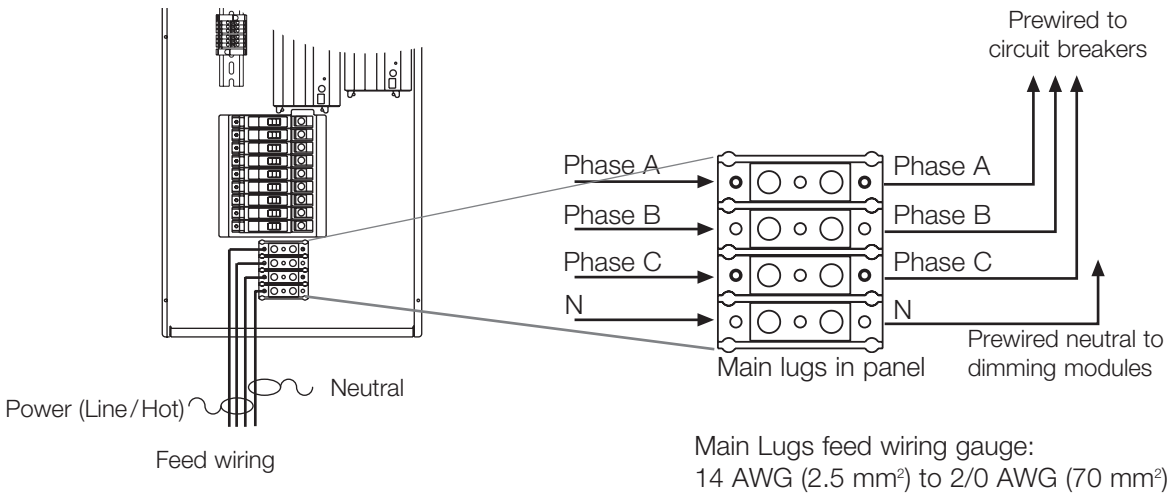

Job Name:	Model Numbers:
Job Number:	

Wiring Details: 120 V~ Mini and Standard-Size Feed-Through Panel

Typical Dimming/Switching Leg

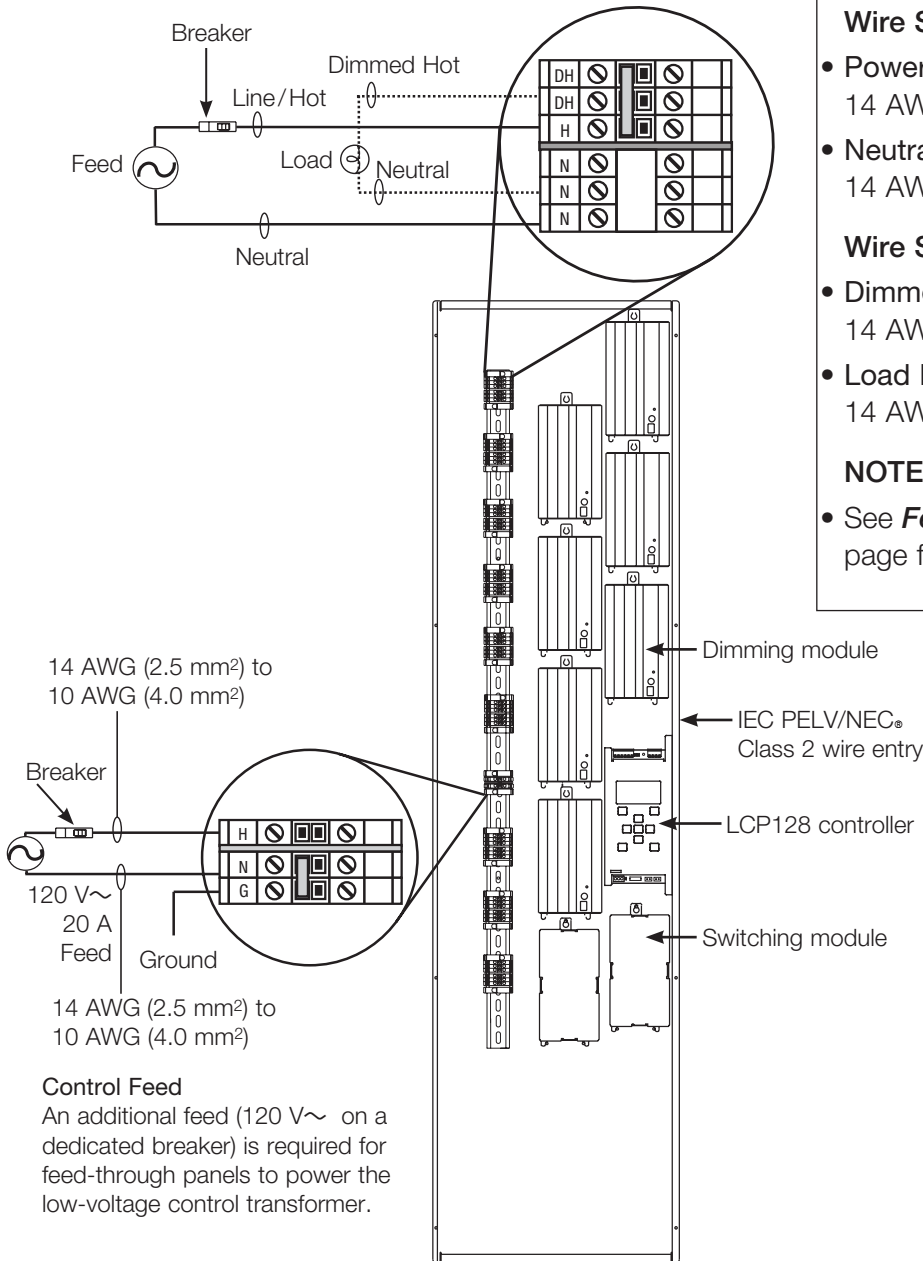

- Wire Sizes for Power Feed, To Each Circuit**
- **Power Feed:**
14 AWG (2.5 mm²) to 10 AWG (4.0 mm²)
 - **Neutral Feed:**
14 AWG (2.5 mm²) to 10 AWG (4.0 mm²)
- Wire Sizes for Load Wiring, From Each Output**
- **Dimmed/Switched Line/Hot (Live):**
14 AWG (2.5 mm²) to 10 AWG (4.0 mm²)
 - **Load Neutral:**
14 AWG (2.5 mm²) to 10 AWG (4.0 mm²)
- NOTES**
- See *Feed and Load Wiring to Terminal Blocks* page for load wiring details.

Job Name:	Model Numbers:
Job Number:	

Feed and Load Wiring to Terminal Blocks: 120 V~ Mini and Standard-Size

General Notes

- Typical dimming/switching legs shown.
 - Do not remove bypass jumpers until after load wiring has been verified.
- Wire sizes for power feed, to each input
- Power feed: 14 AWG (2.5 mm²) to 10 AWG (4.0 mm²)
 - Neutral feed: 14 AWG (2.5 mm²) to 10 AWG (4.0 mm²)
- Wire sizes for load wiring, from each output
- Dimmed/switched Line/Hot (live): 14 AWG (2.5 mm²) to 10 AWG (4.0 mm²)
 - Load neutral: 14 AWG (2.5 mm²) to 10 AWG (4.0 mm²)

Control Feed

An additional feed (120 V~ on a dedicated breaker) is required for feed-through panels to power the low-voltage control transformer.

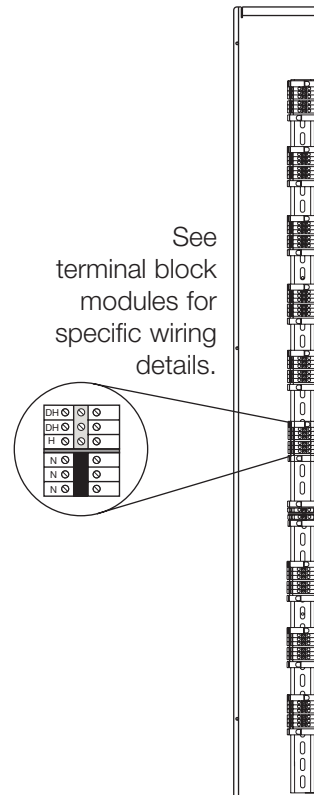

4-Circuit Switching (Relay) Module (XP)

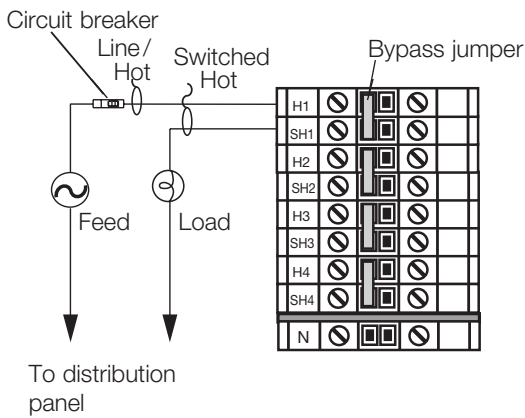

4-Circuit Dimming Module (4U)

4-Circuit Adaptive Dimming Module (4A)

4-Circuit Quiet Fan Speed Module (4FSQ)

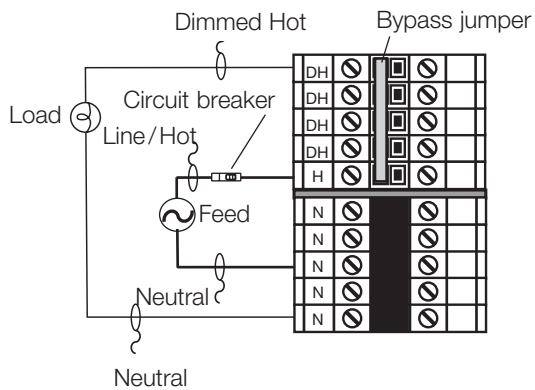

Continued on next page...

Job Name:	Model Numbers:
Job Number:	

Feed and Load Wiring to Terminal Blocks: 120 V~ Mini and Standard-Size (continued)

4-Circuit Motor Module (4M)

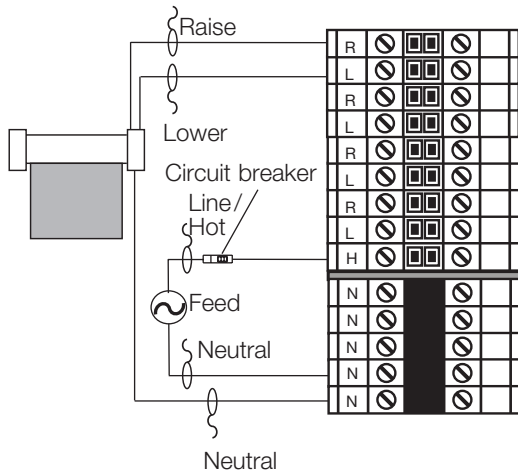

Connecting a PHPM-3F-120-WH or PHPM-3F-DV-WH to a Panel

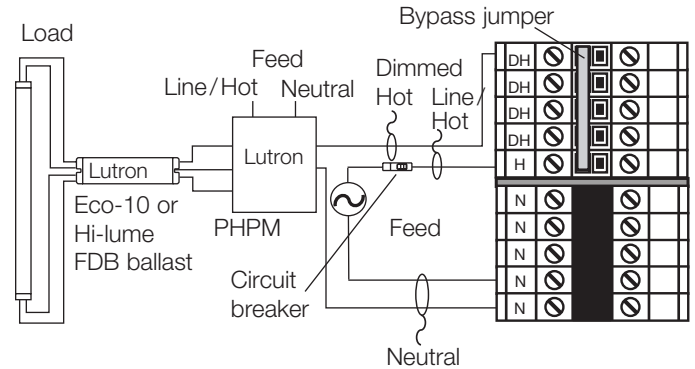

Load feed: 120 V~ if used with PHPM-3F-120-WH power module
120-277 V~ if used with PHPM-3F-DV-WH power module

Refer to PHPM Installation Sheet for detailed wiring.

TVM Module

For 0-10 V \Rightarrow , PWM, Tridonic[®] DSI, and DALI[®] loads. Each TVM controls two consecutive circuits of lighting and are the first circuits in the panel. Maximum low-voltage ballast control current: 50 mA per zone, 750 mA per panel. Dimming or switching module is used to switch power to the ballast.

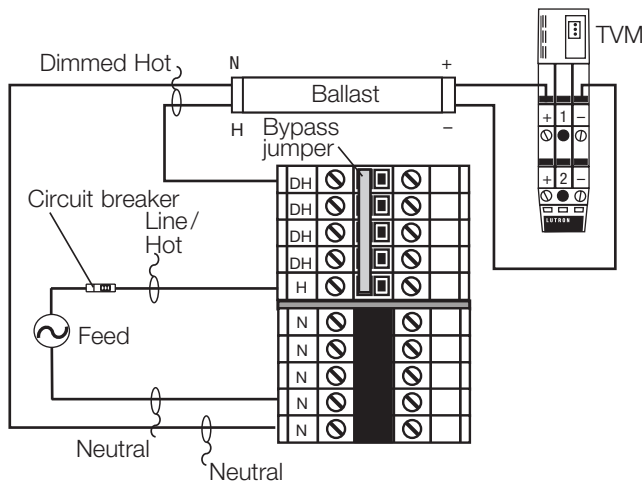

1-Circuit Dimming Module (1U)

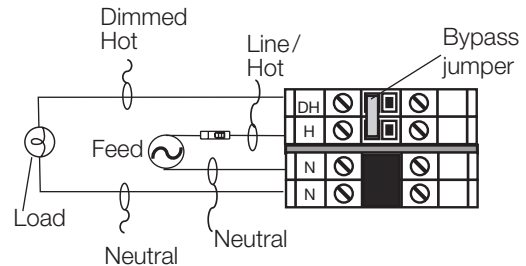

2-Circuit Dimming Module (2U)

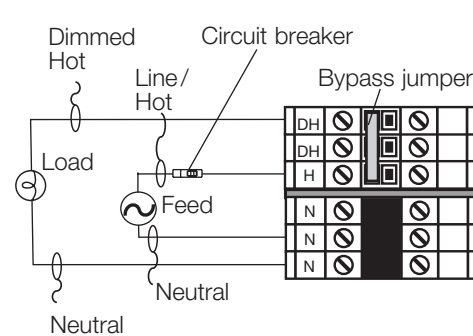

Job Name:	Model Numbers:
Job Number:	

IEC PELV/NEC® Class 2 Wiring

The LCP128 system communicates to control stations using a IEC PELV/NEC® Class 2 low-voltage link.

Control stations include wallstations, contact closure input and output devices, and RS232 interfaces. Wire the IEC PELV/NEC® Class 2 link according to the following guidelines:

- Link must be daisy chained.
- Must run in separate trough from line (mains) voltage.
- Link must be less than 2000 ft (600 m) long.
- Make wire connections inside the wallbox and LCP128 panel.
- Install Link Terminators (LT-1A) at the start and end of the IEC PELV/NEC® Class 2 daisy-chained link.
- The order of controls on the control link is not important.
- Use Lutron GRX-CBL-46L cable or equivalent.

Maximum total length of the control link is 2000 ft (600 m). This distance is based on proper shielding of the twisted/shielded pair, proper wire size, and the use of link terminators (LT-1A) at each end of the link. If unapproved cable or smaller wire is used control link length must be de-rated according to the following chart:

Terminal 1 & 2 Wire Sizes	Maximum Control Link Length
12 AWG (4.0 mm ²)	2000 ft (600 m)
14 AWG (2.5 mm ²)	1400 ft (425 m)
16 AWG (1.5 mm ²)	900 ft (275 m)
18 AWG (0.75 mm ²)	600 ft (180 m)

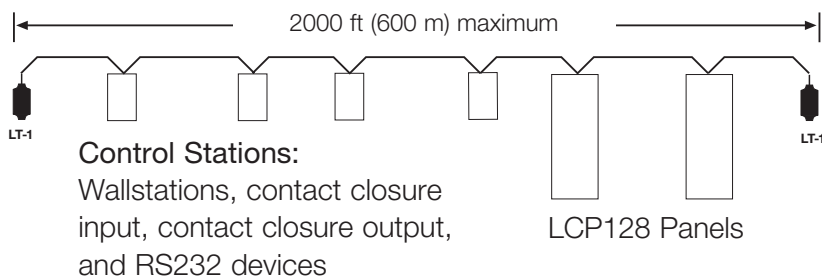

NOTICE: Link Terminators (LT-1A) are required at the start and end of the LCP128 IEC PELV/NEC® Class 2 link. If Link Terminators (LT-1A) are not used or improper wiring topology is employed, the system will not communicate properly.

Lutron, Lutron, Eco-10, Hi-lume, Nova Tr, Softswitch, seeTouch and Tu-Wire are trademarks of Lutron Electronics Co., Inc. registered in the U.S. and other countries.
 LCP128 and HiPower 2•4•6 are trademarks of Lutron Electronics Co., Inc.
 DALI is a registered trademark of DALI Systems Co. Ltd.
 NEC is a registered trademark of National Fire Protection Association, Quincy, Massachusetts
 NEMA is the registered trademark and service mark of the National Electrical Manufacturers Association
 Tridonic DSI is a trademark of TridonicAtco GmbH & Co KG, Dornbirn, Austria.

LUTRON SPECIFICATION SUBMITTAL

Job Name:	Model Numbers:
Job Number:	

IEC PELV/NEC® Class 2 Wiring Panel to Panel and Panel to Control Stations

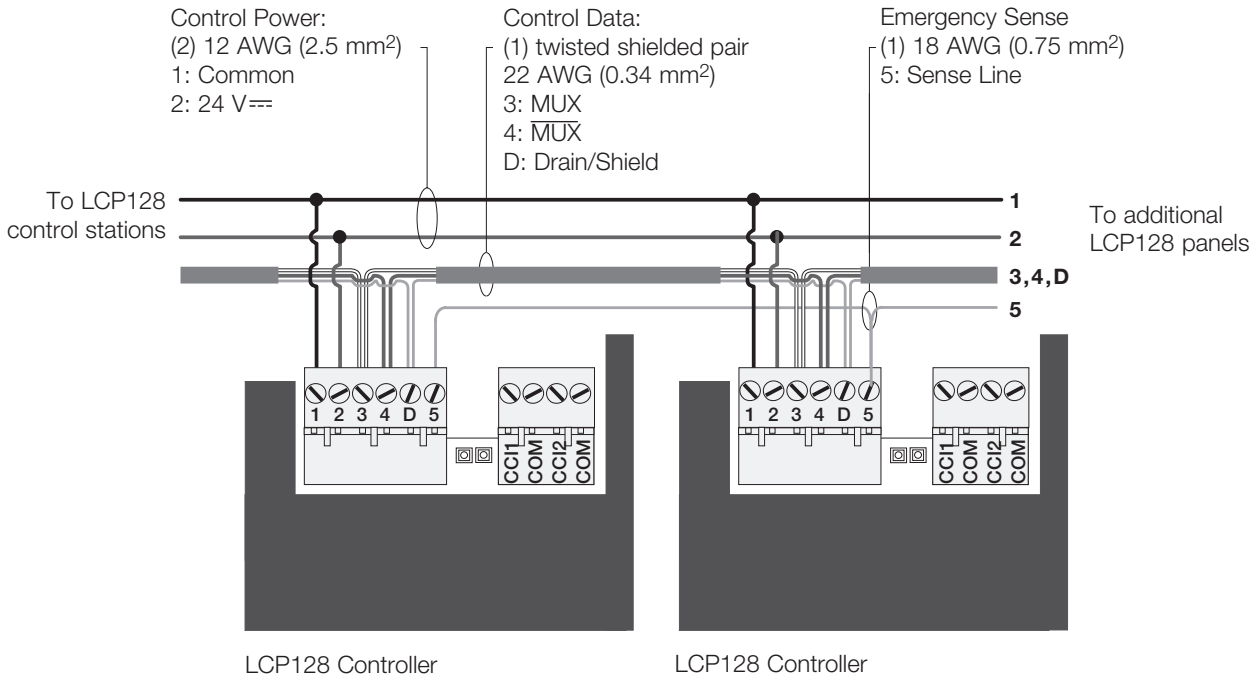

Wiring Notes

- Use a wire connector to attach one 18 AWG (0.75 mm²) wire for Common (terminal 1) and one 18 AWG (0.75 mm²) wire for 24 V_{AC} (terminal 2) from the IEC PELV/NEC® Class 2 link to the control. Two 12 AWG (4.0 mm²) wires cannot both be terminated on the control station. Maximum wire length from link to control is 8 ft (2.5 m).
- Only connect the Drain/Shield wire (bare copper) to terminal 'D' in LCP128 panels. Maintain the shield throughout the link but do not allow it to touch ground (earth) or wallstation circuitry.

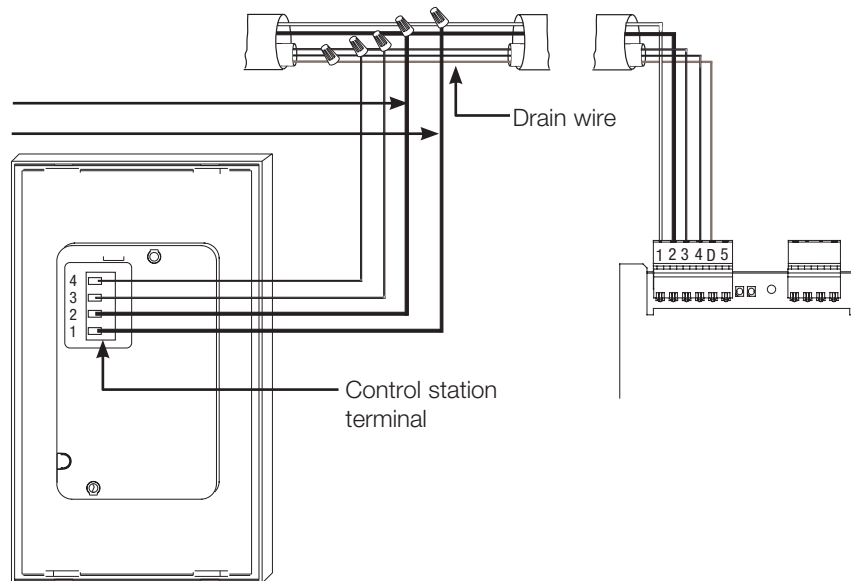

Job Name:	Model Numbers:
Job Number:	