

PALLADIOM SHADE

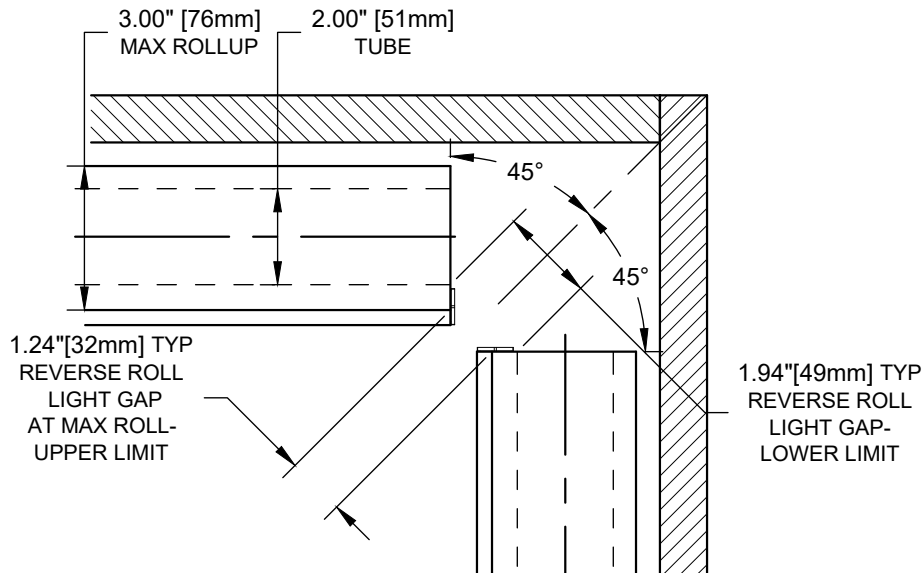

CORNER TO CORNER TYPICAL DETAILS

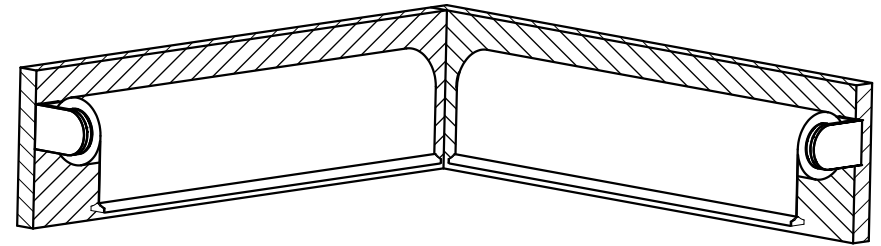

SCALE: 1/5

WALL MOUNT BRACKET SHOWN

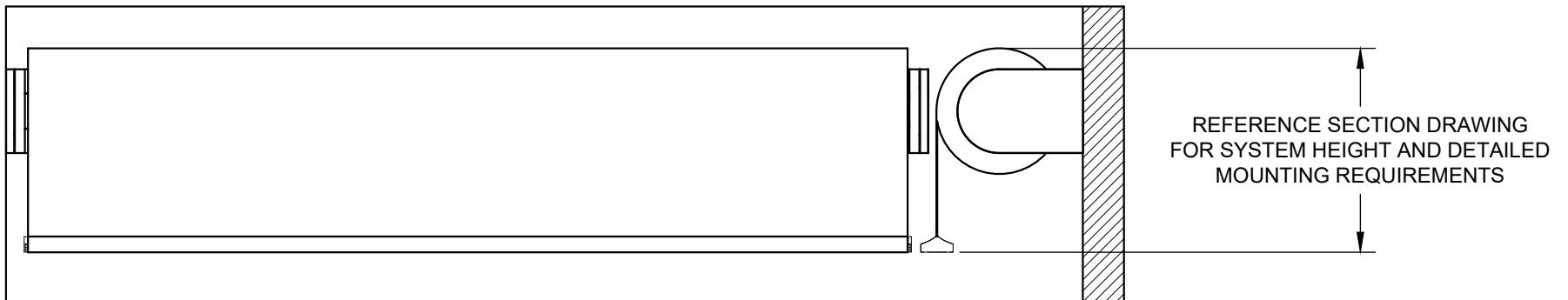

SHADE INSTALLED AS PROVIDED BY FACTORY WILL HAVE ALL NECESSARY CLEARANCES FOR PROPER OPERATION. IT IS THE RESPONSIBILITY OF THE MASTER TECHNICIAN TO ENSURE PROPER CLEARANCES ARE MAINTAINED AFTER INSTALLATION. **MINIMUM RECOMMENDED DEDUCTIONS BASED ON 90° CORNER.**

PALLADIOM SHADE CORNER INSTALLATION

085633

SCALE: 1/4

PAGE: 1

REVISION: C



Lutron Electronics Co., Inc.
7200 Suter Road | Coopersburg, PA 18036 | USA
1(800) 446-1503 | Fax: (610) 282-7439
<http://www.lutron.com>

AUXILIARY VIEWS

PALLADIOM SHADE

CORNER TO CORNER BRACKET DETAILS

CEILING

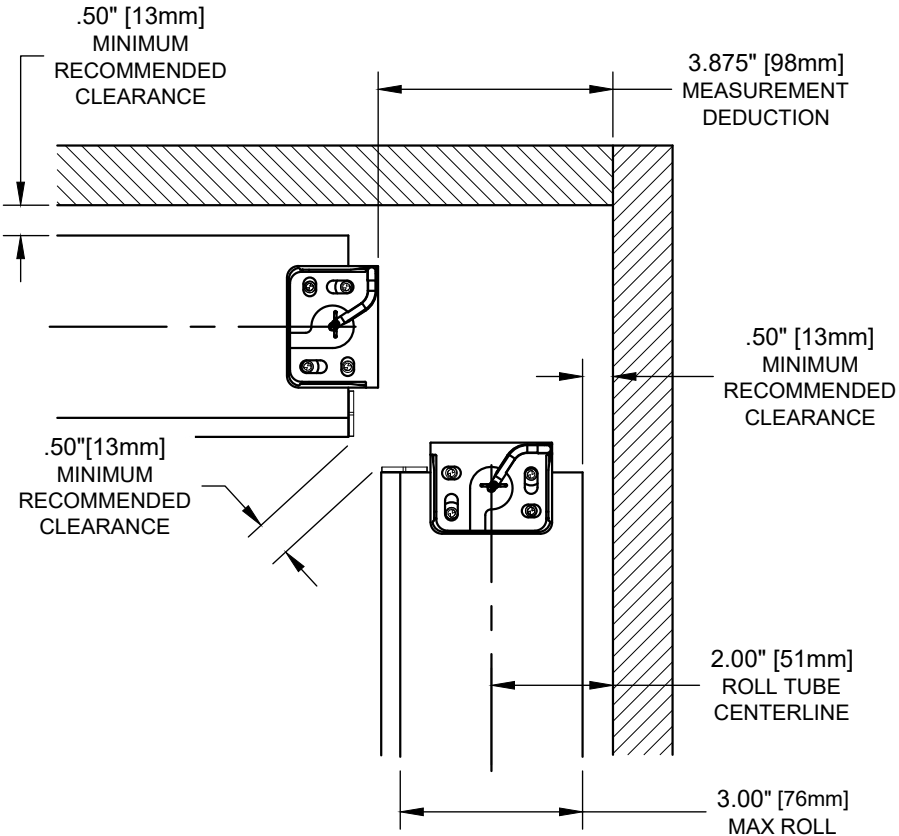

WALL

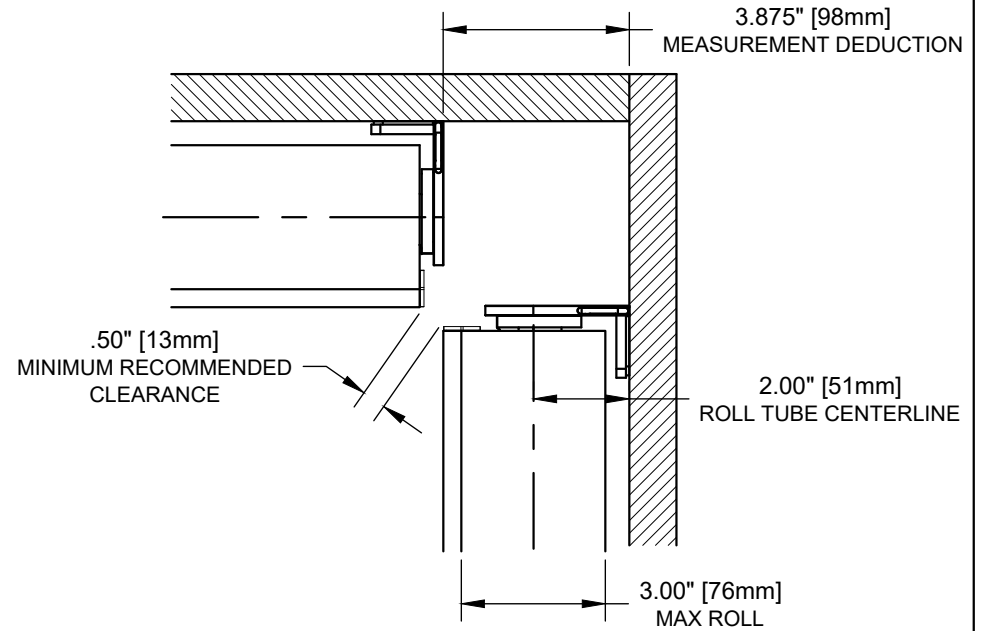

SHADE INSTALLED AS PROVIDED BY FACTORY WILL HAVE ALL NECESSARY CLEARANCES FOR PROPER OPERATION. IT IS THE RESPONSIBILITY OF THE MASTER TECHNICIAN TO ENSURE PROPER CLEARANCES ARE MAINTAINED AFTER INSTALLATION. **MINIMUM RECOMMENDED DEDUCTIONS BASED ON 90° CORNER.**

PALLADIOM SHADE CORNER INSTALLATION

085633

SCALE: 1/4

PAGE: 2

REVISION: B



Lutron Electronics Co., Inc.
7200 Suter Road | Coopersburg, PA 18036 | USA
1(800) 446-1503 | Fax: (610) 282-7439
<http://www.lutron.com>

TOP VIEWS