

# PALLADIOM

WIRE-FREE SHADING SYSTEM

---

Automated shading without compromise

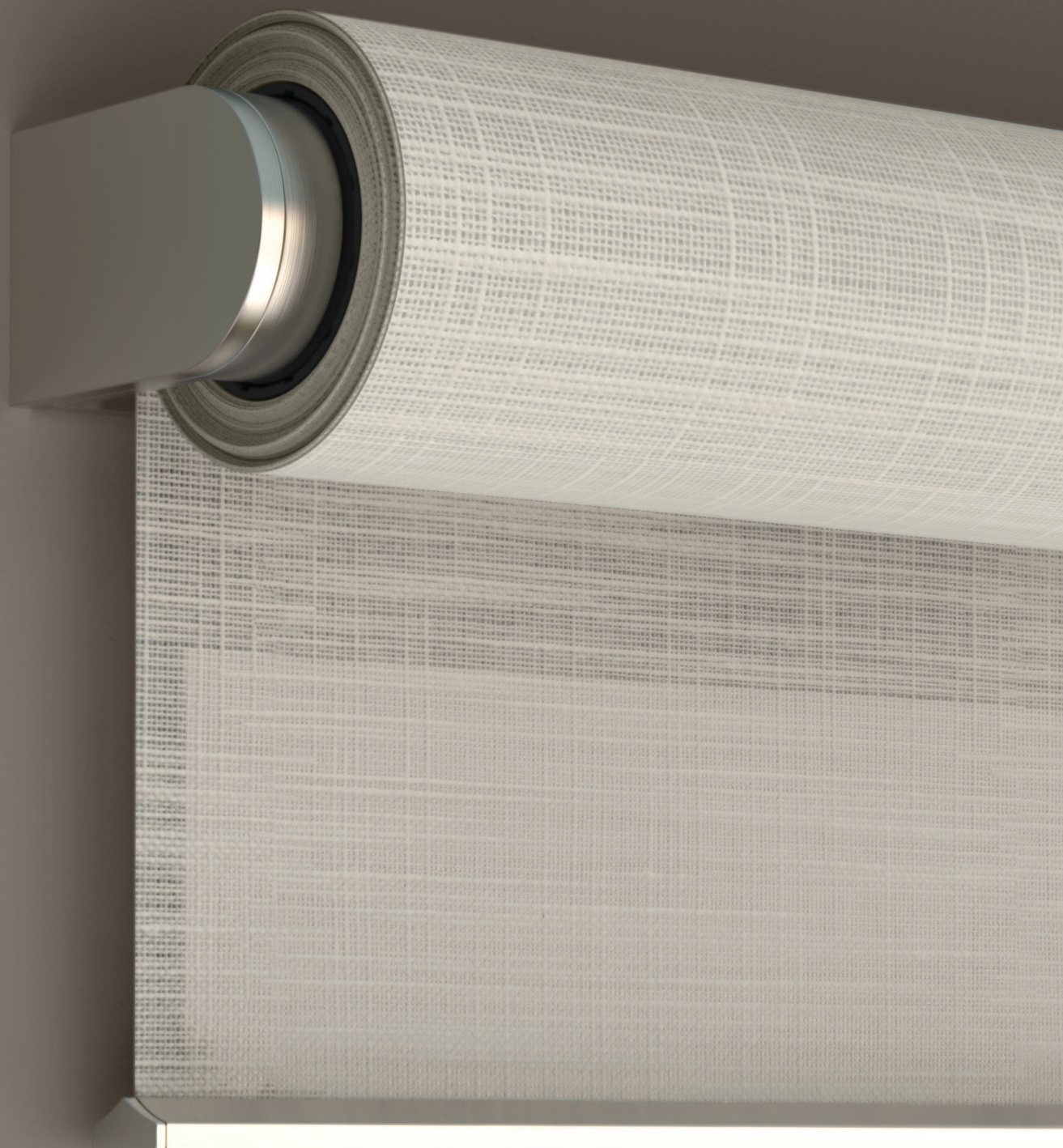



Introducing Palladiom Wire-Free Shading System, Lutron's premier solution for exquisite homes. This intelligent system delivers the ultimate design freedom — a stunning blend of beauty, flexibility, and performance without sacrifice.



## Inspiring aesthetics

**A flexible solution for design freedom,** Palladiom Wire-Free blinds are intended to be installed without a pocket, fascia, or top treatment. With absolutely nothing to hide, beautiful daylight control can be added to any room of the home, at any time.

**Powered by batteries integrated into the blind itself,** this shading solution is ideal for situations where wired power is not an option.

# Infinite possibilities

**A tailored aesthetic** lets you customise the blind to fit your space. Choose from a selection of seven, hand-finished materials all curated to coordinate with Lutron Palladiom keypads and thermostats, and wired Palladiom blinds. With hundreds of fabrics in a variety of textures and colourways, the design options are endless.

**Show off expansive views.** Palladiom Wire-Free blinds can be used for windows up to 3600mm wide by 3600mm tall, and occupy no more than 82mm of vertical space when the blind is open.

**Every last detail** was carefully considered from the overall design to the blind hembar options. The unique Palladiom Bottom Rail sets a new standard for luxury shading, offering a streamlined aesthetic at the windowsill. Or choose from a variety of fabric-wrapped hembars specifically designed with end caps to match the bracket hardware.



Palladiom Bottom Rail\*



Half-Wrap Architectural Bottom Bar

\*Available in Pure White, Clear Anodized, Black Anodized and Satin Nickel finishes only.

## PALLADIOM BLINDS SYSTEM BRACKET FINISHES

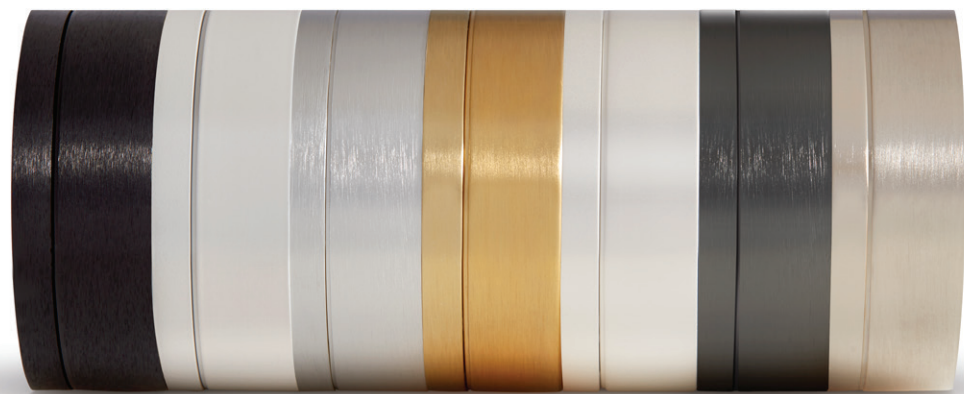

Black Anodized    Pure White    Clear Anodized    Brass    Opal White    Satin Graphite    Satin Nickel

# Any application

**Form factor variety** includes end, center, or jamb offering designers built-in versatility, and allowing you to configure the blind for any window.

## END BRACKET

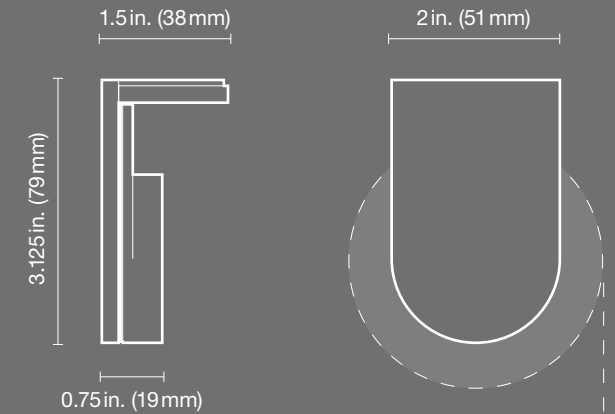
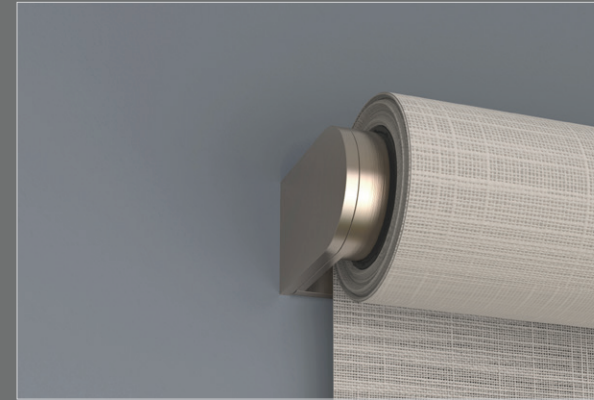

## CENTER BRACKET

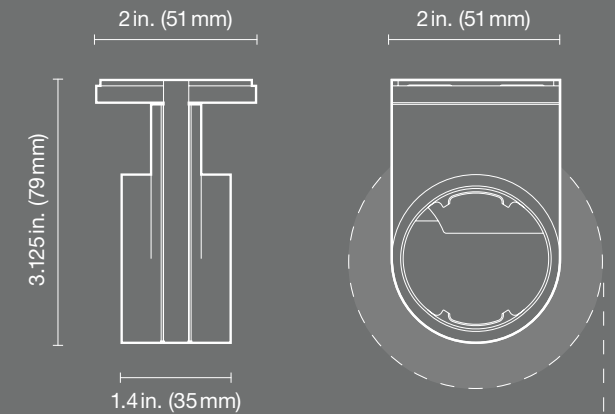
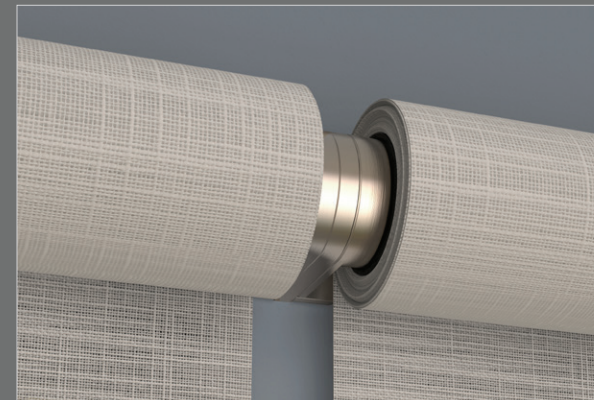

## JAMB BRACKET

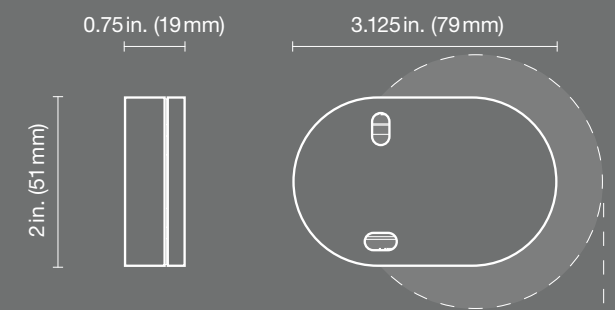
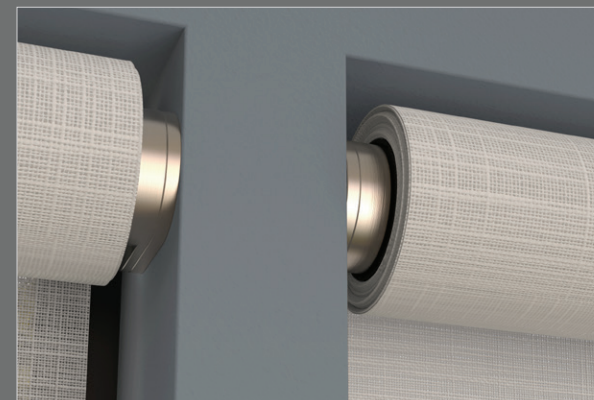



# Unparalleled performance

Over ten years of battery technology and research, combined with 30 years of cutting-edge blind design and development culminate in the most advanced, efficient Lutron battery-powered blind to date.

PALLADIOM  
WIRE-FREE SHADING SYSTEM

**Active Energy Optimisation**, a breakthrough battery-management architecture, was designed to enhance the delicate balance of energy density and power density in traditional alkaline batteries. Using no more than six, off-the-shelf D-cell batteries, these blinds achieve the 3-5 year battery life you've come to expect from Lutron.

**Designed with simplicity in mind**, the Palladiom Wire-Free Shading System boasts a patent-pending bracket mechanism. The replaceable batteries can be easily accessed when needed without taking the blind down, but are otherwise completely hidden from view, housed within the blind drive.





# Astonishingly simple

**Supported by a world-class system**, the Palladiom Wire-Free Shading System integrates seamlessly with the Lutron HomeWorks lighting control system, allowing you to harmoniously combine lighting, blinds, and temperature controls.

**With the convenient Lutron App**, users can set schedules or individually control their blinds from anywhere in the world, at any time. This intelligent system lets users know when batteries are low, and provides visual assistance with the battery-change process.

**A variety of control options** makes blind control easy and intuitive. Choose from beautiful wall-mounted keypads offered in finishes that complement Palladiom blind hardware, remote controls, or even common voice-control platforms.





**[lutron.com/europe](https://lutron.com/europe)**

European Headquarters  
Lutron EA Ltd.  
4th Floor, 52 Leadenhall Street  
London EC3A 2EB, UK

European Experience Centre  
4th Floor, 125 Finsbury Pavement  
London EC2A 1NQ, UK  
FREEPHONE: 0800 282 107  
TEL: +44 (0) 207 702 0657  
[euroexperience@lutron.com](mailto:euroexperience@lutron.com)

**Customer Assistance**

Online: [lutron.com](https://lutron.com) | Email: [eacs@lutron.com](mailto:eacs@lutron.com) | Phone: +44.(0) 207 680.4481

Lutron is a trademark of Lutron Electronics Co., Inc., registered in the U.S. and other countries.  
For a complete list of all Lutron registered and common law trademarks, please visit [lutron.com/trademarks](https://lutron.com/trademarks)